

PREVIEW-MY20 COMPLETE BIKES - 0W/4

RBC.

LEON HOPPE - photo: Aaron Zwaal



RADIO™

INDEX-RBC

JACK CLARK - photo: Aaron Zwaal

pp. 04 -06
pp. 07 -09
pp. 10 -12
pp. 13 -15
pp. 16 -18

REVO 14 inch
REVO 16 inch
REVO 18 inch
REVO 20 inch
REVO PRO 20 inch

pp. 20 -22
pp. 23 -25
pp. 26 -28
pp. 29 -31
pp. 32 -34
pp. 35 -37
pp. 38 -40
pp. 41 -43
pp. 44 -45
pp. 46 -47
pp. 48 -49

DICE 16 inch
DICE 18 inch
DICE 20 inch
DICE FS 20 inch
EVOL 20 inch
SAIKO 18 inch
SAIKO 20 inch
DARKO 20 inch
VALAC 20 inch
ASTRON 20 inch
COMRAD 20 inch

pp. 50 -51
pp. 52 -53
pp. 54 -55
pp. 56 -57
pp. 58 -59
pp. 60 -61

FIEND 26 inch
GRIFFIN 26 inch
GRIFFIN PRO 26 inch
SIREN 26 inch
ASURA 26 inch
ASURA PRO 26 inch

pp. 62 -63
pp. 64 -65
pp. 66 -67
pp. 68 -69

LEGION 26 inch
LEGION 29 inch
CEPTOR 26 inch
DIVIDE 700 c





THIS IS RADIO-MY20

WHO IS RADIO?-NOT JUST A BIKE COMPANY

Born from the foundations of one of the most successful and innovative rider owned bike companies of the 1990's Radio Bikes is proud to enter the dawn of it's second decade with a new focus and drive, cementing the core principals of the brand and bringing high quality and well-designed bikes to a wide array of customers across the globe.

We see each complete bike as an opportunity to give our customers a product that will inspire and ignite a life long love of riding bikes. Every Radio product is meticulously thought through, designed and constructed in a way to ensure that the bike looks and performs unlike anything else - on a budget to suit every form of rider.

Designed, developed, ridden and run by a team of dedicated bike riders, every Radio Bikes product is made with an injection of pure passion and innovation, all whilst having a constant finger on the fast beating pulse of the bike industry.

WHO IS A RADIO COSTUMER?-EVERYONE...

Far from just another generic brand to "fill in the gaps", Radio Bikes is unlike any other brand on the market. Radio was born out of the need for a line of bikes, that simply just didn't exist. Where many brands try to reduce the cost of the bike through downgrading quality and using cheaper components - we see a chance to innovate the design and to ensure the bike functions just as well, but at a more competitive price.

Every year that has passed, we have built onto the principal and now

the Radio Bikes line has evolved, refined and grown into the all-encompassing range, that caters to the need of every bike rider. From a 14" REVO for first time rider, an 18" Alloy DICE for the younger rider wanting to progress on a lighter bike, 26" and 29" LEGION wheelie bikes for the new wave of urban warriors, all the way to the PRO-level 26" SIREN Slopestyle bike for experienced mountain bike riders, **Radio has something for every customer!**

WHAT IS RADIO IN 2020?-BEYOND THE BIKE.

2020 is the year that Radio goes beyond. Radio has the unique advantage of being one of the most flexible and reputable bike companies on the market, and this is the year that we fully seal this claim. Having the past 10 years to solidify our direction and product line, this year is the year that Radio rises to take it's place among it's sister brands and is seen for the global all-encompassing bicycle brand it was always destined to be.

2020 is going to be a year that we **work together with distributions on a global level to build the brand presence of Radio** through event sponsorships, new PRO team riders, product innovations, world tours, increased media attention and jaw dropping video parts which will all be seen on a global level.

Our goal for this year is to make Radio Bikes a brand, that is talked about in every bike shop, at every skatepark and on every street corner.

If you love bikes, you'll love Radio.



REVO-14 INCH

PLEASE NOTE: Final product may vary in appearance.

RADIO BIKE CO.-MY 2020



R

PLEASE NOTE: Final product may vary in appearance.

REVO-14 INCH

R



RADIO BIKE CO.-MY 2020

REVO-14 INCH

RADIO BIKE CO.-MY 2020

FRAME	full 1020 hi-ten
FORK	RADIO "ROOKIE" hi-ten fork
BAR	hi-ten bar
GRIPS	RADIO "JUNIOR" grips
STEM	RADIO "JUNIOR" top load stem, 40mm reach
HEADSET	FSA "A-HEADSET" loose ball
GYRO	-
LEVER	RADIO "JUNIOR" alloy brake lever, front & rear
BRAKES	RADIO "AM" alloy caliper brake front/RADIO "AM-V" alloy v-brake rear
CRANKS	RADIO "ROOKIE" OPC forged crank crmo 102mm
BB	USA size, loose ball
PEDALS	RADIO "ROOKIE" nylon pedals
CHAIN	KMC "S1" chain
SPROCKET	RADIO "ROOKIE" steel 25T sprocket
DRIVER	9T cassette driver
FRONT HUB	RADIO "ROOKIE" steel hub, lb, 20h
REAR HUB	RADIO "ROOKIE" cassette hub, lb, 9T, 20h
FRONT RIM	RADIO "ROOKIE" rim, single wall
REAR RIM	RADIO "ROOKIE" rim, single wall
SEAT	RADIO "CENTURY" railed seat
SEAT POST	RADIO "AM" alloy seat post
SEAT CLAMP	alloy seat clamp
TIRES	RADIO "ROOKIE" tires, 14" x 2.0" front & rear
PEGS	-
WEIGHT	9.48kg / 20.8lbs

COLOR black metallic cyan

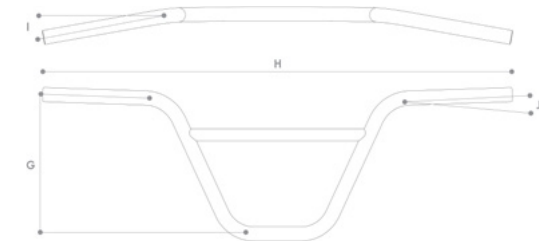
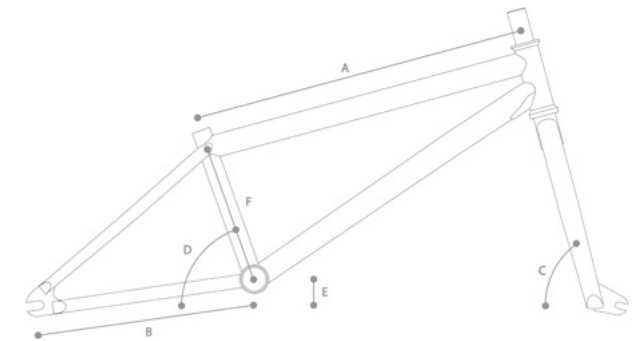

A - TOP TUBE LENGTH	14.5"	BAR GEOMETRY	
B - CHAIN STAY LENGTH	10.6"	G - RISE	6.5"
C - HEAD TUBE ANGLE	72°	H - WIDTH	22.4"
D - SEAT TUBE ANGLE	73°	I - BACKSWEEP	10°
E - BB HEIGHT	8.75"	J - UPSWEEP	3°
F - STANDOVER HEIGHT	5.5"		

PLEASE NOTE: Final product may vary in appearance.

REVO-16 INCH

R



RADIO BIKE CO.-MY 2020

REVO-16 INCH

PLEASE NOTE: Final product may vary in appearance.

RADIO BIKE CO.-MY 2020



R



REVO-16 INCH

FRAME	full 1020 hi-ten
FORK	RADIO "ROOKIE" hi-ten fork
BAR	hi-ten bar
GRIPS	RADIO "JUNIOR" grips
STEM	RADIO "JUNIOR" top load stem, 40mm reach
HEADSET	FSA "A-HEADSET" loose ball
GYRO	-
LEVER	RADIO "JUNIOR" alloy brake lever, front & rear
BRAKES	RADIO "AM" alloy caliper brake front/RADIO "AM-U" alloy u-brake rear
CRANKS	RADIO "ROOKIE" OPC forged crank crmo 140mm
BB	USA size, loose ball
PEDALS	RADIO "ROOKIE" nylon pedals
CHAIN	KMC "S1" chain
SPROCKET	RADIO "ROOKIE" steel 25T sprocket
DRIVER	9T cassette driver
FRONT HUB	RADIO "ROOKIE" steel hub, lb, 28h
REAR HUB	RADIO "ROOKIE" cassette hub, lb, 9T, 28h
FRONT RIM	RADIO "ROOKIE" rim, single wall
REAR RIM	RADIO "ROOKIE" rim, single wall
SEAT	RADIO "CENTURY" railed seat
SEAT POST	RADIO "AM" alloy seat post
SEAT CLAMP	alloy seat clamp
TIRES	RADIO "ROOKIE" tires, 16" x 2.25" front & rear
PEGS	-
WEIGHT	10.42kg / 22.9lbs

COLOR black lime

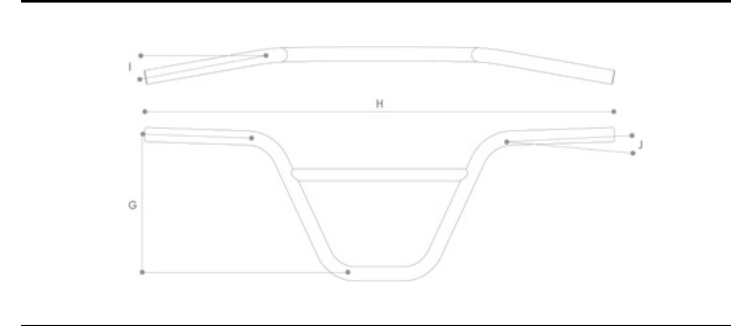
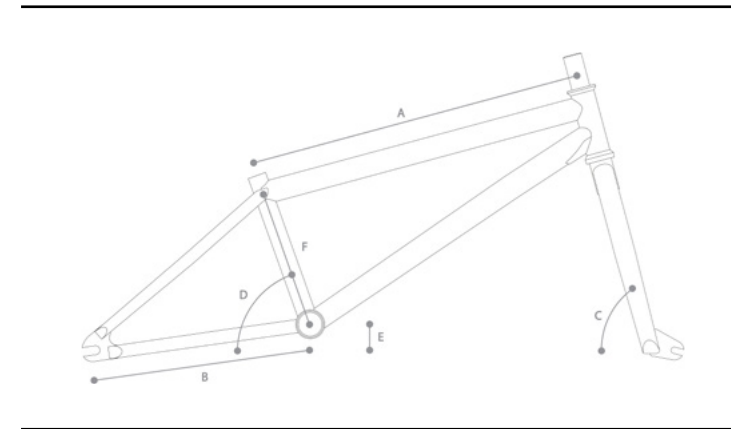

A - TOP TUBE LENGTH	15.75"	BAR GEOMETRY	
B - CHAIN STAY LENGTH	10.8"	G - RISE	6.8"
C - HEAD TUBE ANGLE	75°	H - WIDTH	23.6"
D - SEAT TUBE ANGLE	71.5°	I - BACKSWEEP	10°
E - BB HEIGHT	9.75"	J - UPSWEEP	3°
F - STANDOVER HEIGHT	6.6"		

RADIO BIKE CO.-MY 2020

REVO-18 INCH

PLEASE NOTE: Final product may vary in appearance.

RADIO BIKE CO.-MY 2020



R

PLEASE NOTE: Final product may vary in appearance.

REVO-18 INCH

R



RADIO BIKE CO. - MY 2020

REVO-18 INCH



RADIO BIKE CO.-MY 2020

FRAME	full 1020 hi-ten
FORK	RADIO "ROOKIE" hi-ten fork
BAR	hi-ten bar
GRIPS	RADIO "AM" grips
STEM	RADIO "JUNIOR" top load stem, 40mm reach
HEADSET	FSA "A-HEADSET" loose ball
GYRO	-
LEVER	RADIO "JUNIOR" alloy brake lever, front & rear
BRAKES	RADIO "AM" alloy caliper brake front/RADIO "AM-U" alloy u-brake rear
CRANKS	RADIO "ROOKIE" OPC forged crank crmo 152mm
BB	USA size, loose ball
PEDALS	RADIO "ROOKIE" nylon pedals
CHAIN	KMC "S1" chain
SPROCKET	RADIO "ROOKIE" steel 25T sprocket
DRIVER	9T cassette driver
FRONT HUB	RADIO "ROOKIE" steel hub, lb, 28h
REAR HUB	RADIO "ROOKIE" cassette hub, lb, 9T, 28h
FRONT RIM	RADIO "ROOKIE" rim, single wall
REAR RIM	RADIO "ROOKIE" rim, single wall
SEAT	RADIO "CENTURY" mid padded combo seat
SEAT POST	-
SEAT CLAMP	alloy seat clamp
TIRES	RADIO "ROOKIE" tires, 18" x 2.25" front & rear
PEGS	-
WEIGHT	11.21kg / 24.7lbs

COLOR black red

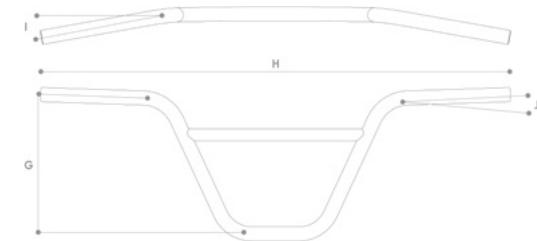
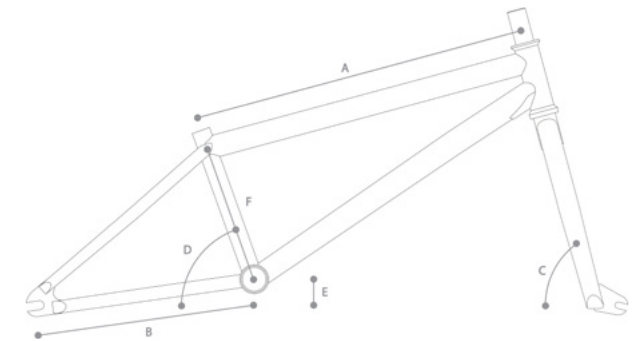

A - TOP TUBE LENGTH	17.55"	BAR GEOMETRY	
B - CHAIN STAY LENGTH	12.55"	G - RISE	7.9"
C - HEAD TUBE ANGLE	75°	H - WIDTH	26.5"
D - SEAT TUBE ANGLE	71.5°	I - BACKSWEEP	10°
E - BB HEIGHT	10.75"	J - UPSWEEP	3°
F - STANDOVER HEIGHT	7.3"		

PLEASE NOTE: Final product may vary in appearance.

REVO-20 INCH

R



RADIO BIKE CO.-MY 2020

REVO-20 INCH

PLEASE NOTE: Final product may vary in appearance.

RADIO BIKE CO.-MY 2020





R



REVO-20 INCH

FRAME	full 1020 hi-ten
FORK	RADIO "ROOKIE" hi-ten fork
BAR	hi-ten bar
GRIPS	RADIO "AM" grips
STEM	RADIO "AM" top load stem, 50mm reach
HEADSET	FSA "A-HEADSET" loose ball
GYRO	-
LEVER	RADIO "AM" alloy brake lever, front & rear
BRAKES	RADIO "AM" alloy caliper brake front/RADIO "AM-U" alloy u-brake rear
CRANKS	RADIO "ROOKIE" OPC forged crank crmo 170mm
BB	USA size, loose ball
PEDALS	RADIO "ROOKIE" nylon pedals
CHAIN	KMC "S1" chain
SPROCKET	RADIO "ROOKIE" steel 25T sprocket
DRIVER	9T cassette driver
FRONT HUB	RADIO "ROOKIE" steel hub, lb, 36h
REAR HUB	RADIO "ROOKIE" cassette hub, lb, 9T, 36h
FRONT RIM	RADIO "ROOKIE" rim, single wall
REAR RIM	RADIO "ROOKIE" rim, single wall
SEAT	RADIO "CENTURY" mid padded combo seat
SEAT POST	-
SEAT CLAMP	alloy seat clamp
TIRES	RADIO "ROOKIE" tires, 20" x 2.25" front & rear
PEGS	-
WEIGHT	12.35kgs / 27.2lbs

COLOR  black  orange

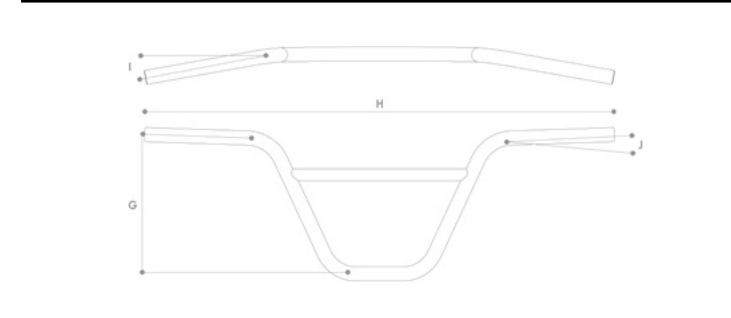
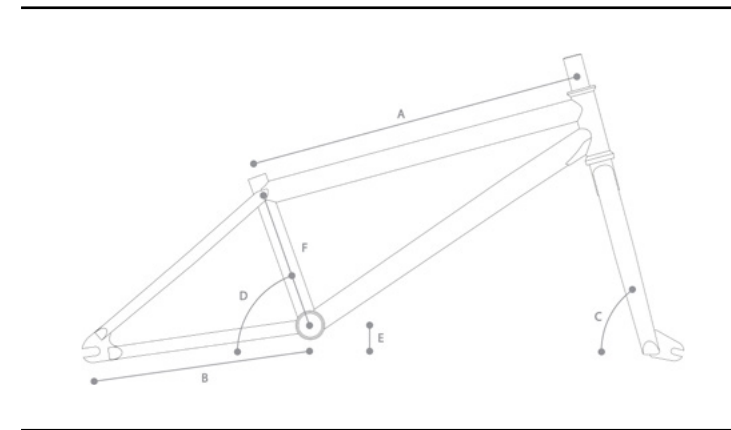

A - TOP TUBE LENGTH	20"	BAR GEOMETRY	
B - CHAIN STAY LENGTH	13.2"	G - RISE	8.6"
C - HEAD TUBE ANGLE	75°	H - WIDTH	28.75"
D - SEAT TUBE ANGLE	71.5°	I - BACKSWEEP	11°
E - BB HEIGHT	11.75"	J - UPSWEEP	2°
F - STANDOVER HEIGHT	7.9"		

RADIO BIKE CO.-MY 2020

REVO PRO-20 INCH

PLEASE NOTE: Final product may vary in appearance.

RADIO BIKE CO.-MY 2020



R

PLEASE NOTE: Final product may vary in appearance.

REVO PRO-20 INCH

R



RADIO BIKE CO.-MY 2020

REVO PRO-20 INCH



RADIO BIKE CO.-MY 2020

FRAME	full 1020 hi-ten
FORK	RADIO "ROOKIE" hi-ten fork
BAR	hi-ten bar
GRIPS	RADIO "AM" grips
STEM	RADIO "AM" top load stem, 50mm reach
HEADSET	FSA "A-HEADSET" loose ball
GYRO	-
LEVER	RADIO "AM" alloy brake lever, front & rear
BRAKES	RADIO "AM" alloy caliper brake front/RADIO "AM-U" alloy u-brake rear
CRANKS	RADIO "AM" 3PC forged crank crmo 165mm
BB	USA size, loose ball
PEDALS	RADIO "ROOKIE" nylon pedals
CHAIN	KMC "S1" chain
SPROCKET	RADIO "ROOKIE" steel 25T sprocket
DRIVER	9T cassette driver
FRONT HUB	RADIO "ROOKIE" steel hub, lb, 36h
REAR HUB	RADIO "ROOKIE" cassette hub, lb, 9T, 36h
FRONT RIM	RADIO "ROOKIE" rim, single wall
REAR RIM	RADIO "ROOKIE" rim, single wall
SEAT	RADIO "CENTURY" mid padded combo seat
SEAT POST	-
SEAT CLAMP	alloy seat clamp
TIRES	RADIO "ROOKIE" tires, 20" x 2.25" front & rear
PEGS	-
WEIGHT	12.63kgs / 27.8lbs

COLOR black orange

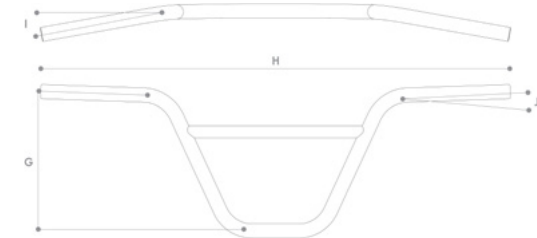
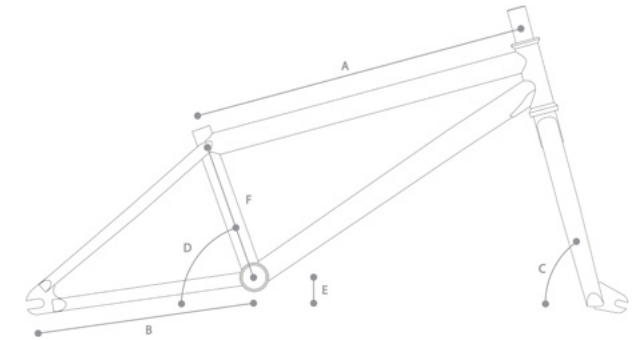

A - TOP TUBE LENGTH	20"	BAR GEOMETRY	
B - CHAIN STAY LENGTH	13.2"	G - RISE	8.6"
C - HEAD TUBE ANGLE	75°	H - WIDTH	28.75"
D - SEAT TUBE ANGLE	71.5°	I - BACKSWEEP	11°
E - BB HEIGHT	11.75"	J - UPSWEEP	2°
F - STANDOVER HEIGHT	7.9"		

RBC.

LEON HOPPE - photo: Aaron Zwaal



RADIOTM

RADIO BIKE CO



DICE-16 INCH

PLEASE NOTE: Final product may vary in appearance.



PLEASE NOTE:
Full 6061 alloy frame

RADIO BIKE CO.-MY 2020



R

PLEASE NOTE: Final product may vary in appearance.

DICE-16 INCH



PLEASE NOTE:
Full 6061 alloy frame

R



RADIO BIKE CO.-MY 2020

DICE-16 INCH



RADIO BIKE CO.-MY 2020

FRAME	full 6061 alloy
FORK	RADIO "ROOKIE 16" 1020 hi-ten fork, tapered legs
BAR	RADIO "ROOKIE 16" bar, 1020 hi-ten
GRIPS	RADIO "AM" grips
STEM	RADIO "JUNIOR" top load stem, 40mm reach
HEADSET	FSA "A-HEADSET" loose ball
GYRO	-
LEVER	RADIO "AM" alloy brake lever, front & rear
BRAKES	RADIO "AM" alloy caliper brake front / RADIO "AM-U" alloy u-brake rear
CRANKS	RADIO "ROOKIE" tubular 3pc crank crmo 140mm, 8 spline
BB	BSA (68), 19mm, sealed
PEDALS	RADIO "VP225" nylon/fiberglass pedals
CHAIN	KMC "S1" chain
SPROCKET	RADIO "ROOKIE" steel 25T sprocket
DRIVER	10T cassette driver, lb
FRONT HUB	RADIO "AM" alloy hub, lb, 3/8"s male axle, 28h
REAR HUB	RADIO "AM" cassette hub, semi-sealed, 10t, 14mm axle, 28h
FRONT RIM	RADIO "ROOKIE" rim, single wall
REAR RIM	RADIO "ROOKIE" rim, single wall
SEAT	RADIO "ROOKIE" combo seat
SEAT POST	-
SEAT CLAMP	alloy seat clamp
TIRES	SALT "TRACER" tires, 2.2" front & rear
PEGS	-
WEIGHT	tba kg / tba lbs

COLOR matt black neon green

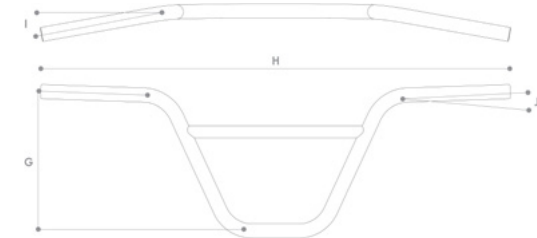
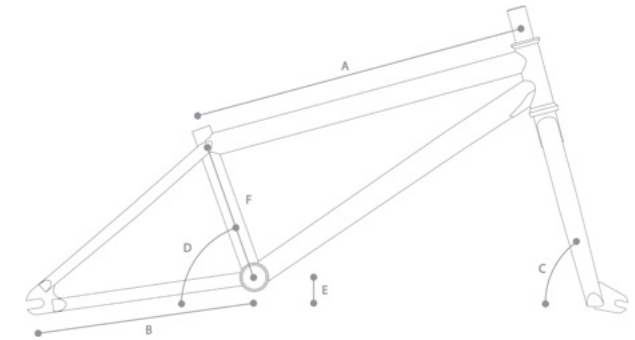

A - TOP TUBE LENGTH	16"	BAR GEOMETRY	
B - CHAIN STAY LENGTH	11.1"	G - RISE	6.75"
C - HEAD TUBE ANGLE	75°	H - WIDTH	23.6"
D - SEAT TUBE ANGLE	71.5°	I - BACKSWEEP	10°
E - BB HEIGHT	9.75"	J - UPSWEEP	3°
F - STANDOVER HEIGHT	6.2"		

PLEASE NOTE: Final product may vary in appearance.

DICE-18 INCH



PLEASE NOTE:
Full 6061 alloy frame

R



RADIO BIKE CO.-MY 2020

DICE-18 INCH

PLEASE NOTE: Final product may vary in appearance.



PLEASE NOTE:
Full 6061 alloy frame

RADIO BIKE CO.-MY 2020



R



DICE-18 INCH

FRAME	full 6061 alloy
FORK	RADIO "ROOKIE 18" 1020 hi-ten fork, tapered legs
BAR	RADIO "ROOKIE 18" bar, 1020 hi-ten
GRIPS	RADIO "AM" grips
STEM	RADIO "JUNIOR" top load stem, 40mm reach
HEADSET	FSA "A-HEADSET" loose ball
GYRO	-
LEVER	RADIO "AM" alloy brake lever, rear
BRAKES	RADIO "AM" alloy u-brake rear
CRANKS	RADIO "ROOKIE" tubular 3pc crank crmo 152mm, 8 spline
BB	BSA (68), 19mm, sealed
PEDALS	RADIO "VP536" nylon/fiberglass pedals
CHAIN	KMC "S1" chain
SPROCKET	RADIO "ROOKIE" steel 25T sprocket
DRIVER	10T cassette driver, lb
FRONT HUB	RADIO "AM" alloy hub, lb, 3/8"s male axle, 36h
REAR HUB	RADIO "AM" cassette hub, semi-sealed, 10t, 14mm axle, 36h
FRONT RIM	RADIO "ROOKIE" rim, single wall
REAR RIM	RADIO "ROOKIE" rim, single wall
SEAT	RADIO "CENTURY" slim padded combo seat
SEAT POST	-
SEAT CLAMP	alloy seat clamp
TIRES	SALT "TRACER" tires, 2.2" front & rear
PEGS	-
WEIGHT	tba kg / tba lbs

COLOR matt black neon green

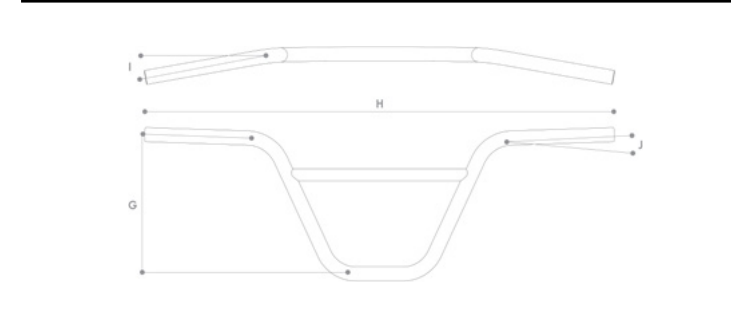
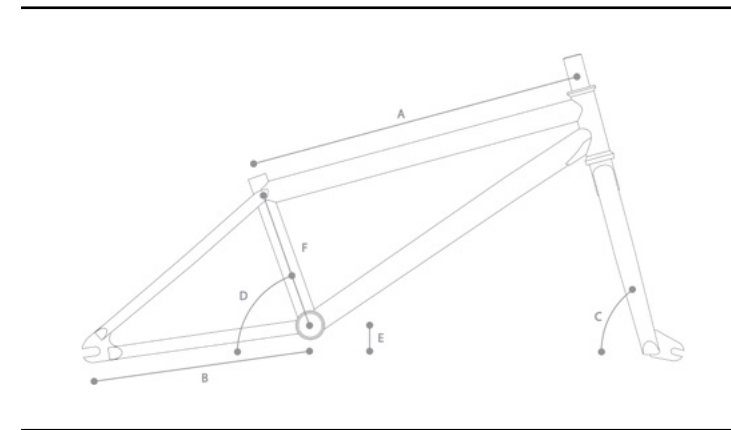

A - TOP TUBE LENGTH	18"	BAR GEOMETRY	
B - CHAIN STAY LENGTH	12.2"	G - RISE	7.9"
C - HEAD TUBE ANGLE	75°	H - WIDTH	26.5"
D - SEAT TUBE ANGLE	71.5°	I - BACKSWEEP	10°
E - BB HEIGHT	10.75"	J - UPSWEEP	3°
F - STANDOVER HEIGHT	6.8"		

RADIO BIKE CO.-MY 2020

DICE-20 INCH

PLEASE NOTE: Final product may vary in appearance.

RADIO BIKE CO.-MY 2020



R

PLEASE NOTE: Final product may vary in appearance.

DICE-20 INCH

R



RADIO BIKE CO.-MY 2020

DICE-20 INCH



RADIO BIKE CO.-MY 2020

FRAME	full 1020 hi-ten
FORK	RADIO "ROOKIE 20" 1020 hi-ten fork, tapered legs
BAR	RADIO "ROOKIE 20" bar, 1020 hi-ten
GRIPS	RADIO "AM" grips
STEM	RADIO "AM" top load stem, 50mm reach
HEADSET	FSA "A-HEADSET" loose ball
GYRO	-
LEVER	RADIO "AM" alloy brake lever, rear
BRAKES	RADIO "AM" alloy u-brake rear
CRANKS	RADIO "ROOKIE" tubular 3pc crank crmo 165mm, 8 spline
BB	mid size, press fit, sealed bearing
PEDALS	RADIO "VP536" nylon/fiberglass pedals
CHAIN	KMC "S1" chain
SPROCKET	RADIO "AM" steel 25T sprocket
DRIVER	9T cassette driver, lb
FRONT HUB	RADIO "ROOKIE" steel hub, lb 3/8"s, 36h
REAR HUB	RADIO "AM" cassette hub, semi-sealed, 9t, 14mm axle, 36h
FRONT RIM	RADIO "ROOKIE" rim, single wall
REAR RIM	RADIO "ROOKIE" rim, single wall
SEAT	RADIO "CENTURY" slim padded combo seat
SEAT POST	-
SEAT CLAMP	alloy seat clamp
TIRES	SALT "TRACER" tires, 2.35" front & rear
PEGS	-
WEIGHT	tba kg / tba lbs

COLOR matt black neon green

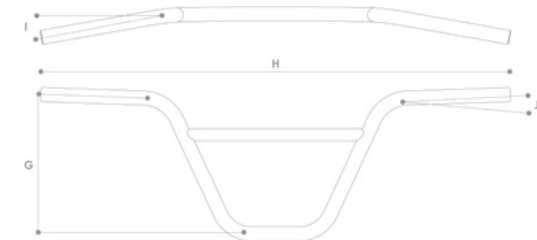
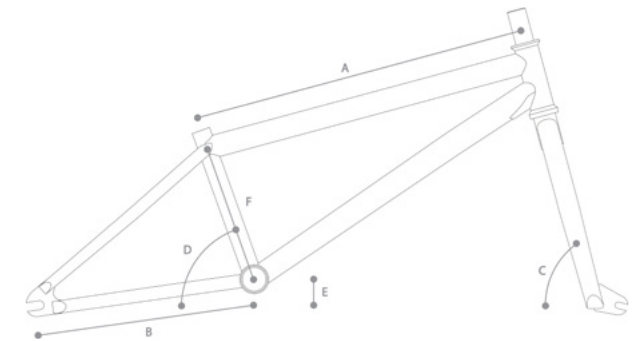

A - TOP TUBE LENGTH	20"	BAR GEOMETRY	
B - CHAIN STAY LENGTH	13.2"	G - RISE	8.8"
C - HEAD TUBE ANGLE	75°	H - WIDTH	28.9"
D - SEAT TUBE ANGLE	71.5°	I - BACKSWEEP	11°
E - BB HEIGHT	11.75"	J - UPSWEEP	2°
F - STANDOVER HEIGHT	7.9"		

PLEASE NOTE: Final product may vary in appearance.

DICE FS-20 INCH

R



RADIO BIKE CO.-MY 2020

DICE FS-20 INCH

PLEASE NOTE: Final product may vary in appearance.

RADIO BIKE CO.-MY 2020



R



DICE FS-20 INCH

FRAME	full 1020 hi-ten
FORK	RADIO "ROOKIE 20" 1020 hi-ten fork, tapered legs
BAR	RADIO "ROOKIE 20" bar, 1020 hi-ten
GRIPS	RADIO "AM" grips
STEM	RADIO "AM" front load stem, 48mm reach
HEADSET	FSA "A-HEADSET" loose ball
GYRO	SALT "AM" rotor with SALT "AM" rotor cables
LEVER	RADIO "AM" alloy brake lever, front & rear
BRAKES	RADIO "AM" alloy u-brake rear
CRANKS	RADIO "ROOKIE" tubular 3pc crank crmo 165mm, 8 spline
BB	mid size, press fit, sealed bearing
PEDALS	RADIO "VP536" nylon/fiberglass pedals
CHAIN	KMC "S1" chain
SPROCKET	RADIO "AM" steel 25T sprocket
DRIVER	9T cassette driver, lb
FRONT HUB	RADIO "ROOKIE" steel hub, lb 3/8"s, 36h
REAR HUB	RADIO "AM" cassette hub, semi-sealed, 9t, 14mm axle, 36h
FRONT RIM	RADIO "ROOKIE" rim, single wall
REAR RIM	RADIO "ROOKIE" rim, single wall
SEAT	RADIO "CENTURY" slim padded combo seat
SEAT POST	-
SEAT CLAMP	alloy seat clamp
TIRES	SALT "TRACER" tires, 2.35" front & rear
PEGS	-
WEIGHT	tba kg / tba lbs

COLOR matt black neon green

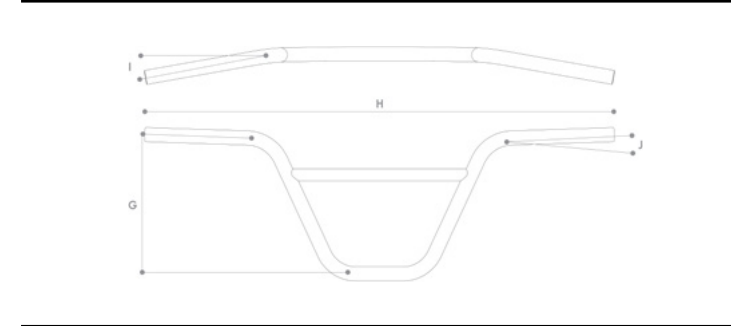
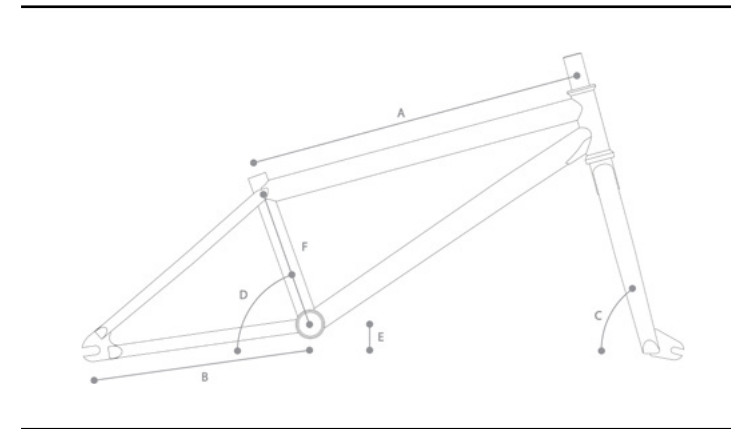

A - TOP TUBE LENGTH	20"	BAR GEOMETRY	
B - CHAIN STAY LENGTH	13.2"	G - RISE	8.8"
C - HEAD TUBE ANGLE	75°	H - WIDTH	28.9"
D - SEAT TUBE ANGLE	71.5°	I - BACKSWEEP	11°
E - BB HEIGHT	11.75"	J - UPSWEEP	2°
F - STANDOVER HEIGHT	7.9"		

RADIO BIKE CO.-MY 2020

EVOL-20 INCH

PLEASE NOTE: Final product may vary in appearance.

RADIO BIKE CO.-MY 2020



R

PLEASE NOTE: Final product may vary in appearance.

EVOL-20 INCH

R



RADIO BIKE CO.-MY 2020

EVOL-20 INCH



RADIO BIKE CO.-MY 2020

FRAME	crmo top tube, 1020 hi-ten
FORK	RADIO "AM" 1020 hi-ten fork, crmo steerer, tapered legs
BAR	RADIO "AM 20" bar, 1020 hi-ten
GRIPS	SALT "EX" grips, flangless
STEM	RADIO "AM" top load stem, 50mm reach
HEADSET	SALT "PRO" int. headset, sealed bearing
GYRO	holes for removable gyro tabs
LEVER	RADIO "AM" alloy brake lever, rear
BRAKES	RADIO "AM" alloy u-brake rear
CRANKS	RADIO "ROOKIE" tubular 3pc crank crmo 165mm, 8 spline
BB	mid size, press fit, sealed bearing
PEDALS	RADIO "PRO" nylon/fiberglass pedals
CHAIN	SALT "AM" chain, Z1 type
SPROCKET	RADIO "VISION" steel 25T sprocket
DRIVER	9T cassette driver, lb
FRONT HUB	RADIO "ROOKIE" steel hub, lb 3/8"s, 36h
REAR HUB	RADIO "AM" cassette hub, semi-sealed, 9t, 14mm axle, 36h
FRONT RIM	RADIO "ROOKIE" rim, single wall
REAR RIM	RADIO "ROOKIE" rim, single wall
SEAT	RADIO "CENTURY" slim padded combo seat
SEAT POST	-
SEAT CLAMP	RADIO "SLIM" alloy seat clamp
TIRES	RADIO "ROOKIE" tires, 2.3" front & rear
PEGS	-
WEIGHT	tba kg / tba lbs

COLOR matt black matt hot pink

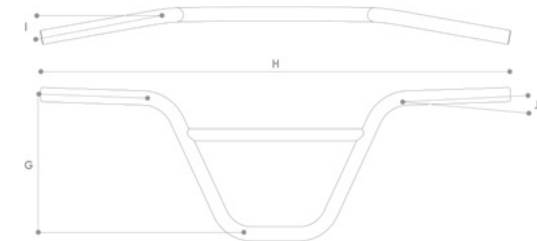
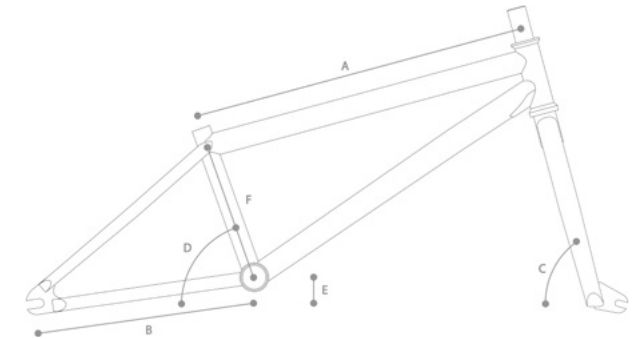

A - TOP TUBE LENGTH	20.3"	BAR GEOMETRY	
B - CHAIN STAY LENGTH	13.2"	G - RISE	8.8"
C - HEAD TUBE ANGLE	75°	H - WIDTH	28.9"
D - SEAT TUBE ANGLE	71.5°	I - BACKSWEEP	11°
E - BB HEIGHT	11.75"	J - UPSWEEP	2°
F - STANDOVER HEIGHT	8.25"		

PLEASE NOTE: Final product may vary in appearance.

SAIKO-18 INCH

R



RADIO BIKE CO.-MY 2020

SAIKO-18 INCH

PLEASE NOTE: Final product may vary in appearance.

RADIO BIKE CO.-MY 2020



R



SAIKO-18 INCH

FRAME	crmo down tube, 1020 hi-ten
FORK	RADIO "SAIKO 18" 1020 hi-ten fork, crmo steerer, tapered legs
BAR	RADIO "AM 18" bar, 1020 hi-ten
GRIPS	RADIO "AM" grips
STEM	SALT "JUNIOR" top load stem, 40mm reach
HEADSET	SALT "PRO" int. headset, sealed bearing
GYRO	holes for removable gyro tabs
LEVER	RADIO "AM" alloy brake lever, rear
BRAKES	RADIO "AM" alloy u-brake rear
CRANKS	RADIO "AM" tubular 3pc crank crmo 152mm, 8 spline
BB	mid size, press fit, sealed bearing
PEDALS	RADIO "PRO" nylon/fiberglass pedals
CHAIN	SALT "AM" chain, Z1 type
SPROCKET	RADIO "VISION" steel 25T sprocket
DRIVER	9T cassette driver, lb
FRONT HUB	RADIO "AM" alloy hub, lb, 3/8"s male axle, 36h
REAR HUB	RADIO "AM" cassette hub, semi-sealed, 9t, 14mm axle, 36h
FRONT RIM	RADIO "AM" rim, single wall
REAR RIM	RADIO "AM" rim, single wall
SEAT	RADIO "CENTURY" slim padded combo seat
SEAT POST	-
SEAT CLAMP	RADIO "SLIM" alloy seat clamp
TIRES	SALT "TRACER" tires, 2.2" front & rear
PEGS	-
WEIGHT	tba kg / tba lbs

COLOR black metallic cyan

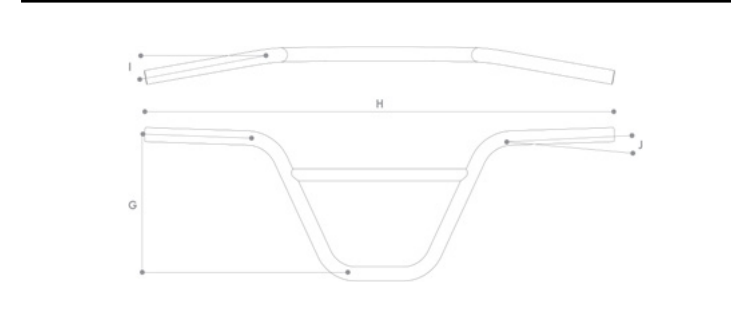
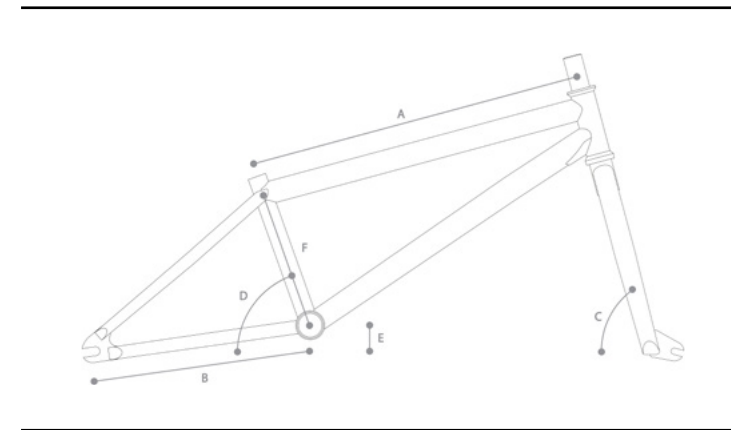

A - TOP TUBE LENGTH	18"	BAR GEOMETRY	
B - CHAIN STAY LENGTH	12.2"	G - RISE	7.9"
C - HEAD TUBE ANGLE	75°	H - WIDTH	26.5"
D - SEAT TUBE ANGLE	70.5°	I - BACKSWEEP	10°
E - BB HEIGHT	10.75"	J - UPSWEEP	3°
F - STANDOVER HEIGHT	7.5"		

RADIO BIKE CO.-MY 2020

SAIKO-20 INCH

PLEASE NOTE: Final product may vary in appearance.

RADIO BIKE CO.-MY 2020



R

PLEASE NOTE: Final product may vary in appearance.

SAIKO-20 INCH

R



RADIO BIKE CO.-MY 2020

SAIKO-20 INCH



RADIO BIKE CO.-MY 2020

FRAME	crmo top tube & down tube, 1020 hi-ten
FORK	RADIO "SAIKO 20" 1020 hi-ten fork, crmo steerer, tapered legs
BAR	RADIO "SAIKO" bar, 1020 hi-ten
GRIPS	RADIO "AM" grips
STEM	SALT "PRO" top load stem, 50mm reach
HEADSET	SALT "PRO" int. headset, sealed bearing
GYRO	holes for removable gyro tabs
LEVER	RADIO "AM" alloy brake lever, rear
BRAKES	RADIO "AM" alloy u-brake rear
CRANKS	RADIO "AM" tubular 3pc crank crmo 165mm, 8 spline
BB	mid size, press fit, sealed bearing
PEDALS	RADIO "PRO" nylon/fiberglass pedals
CHAIN	SALT "AM" chain, Z1 type
SPROCKET	RADIO "VISION" steel 25T sprocket
DRIVER	9T cassette driver, lb
FRONT HUB	RADIO "AM" alloy hub, lb, 3/8"s male axle, 36h
REAR HUB	RADIO "AM" cassette hub, semi-sealed, 9t, 14mm axle, 36h
FRONT RIM	RADIO "AM" rim, single wall
REAR RIM	RADIO "AM" rim, single wall
SEAT	RADIO "CENTURY" slim padded combo seat
SEAT POST	-
SEAT CLAMP	RADIO "SLIM" alloy seat clamp
TIRES	SALT "TRACER" tires, 2.35" front & rear
PEGS	-
WEIGHT	tba kg / tba lbs

COLOR black metallic cyan

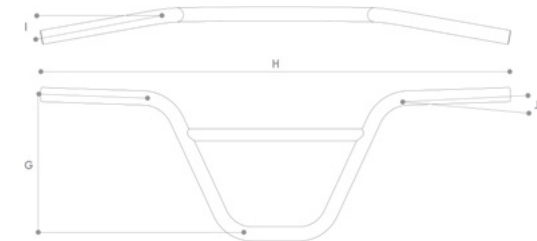
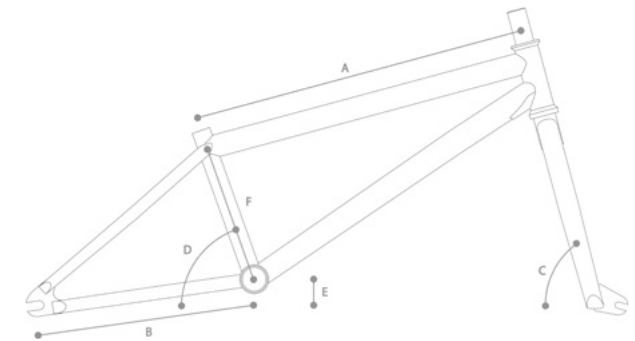

A - TOP TUBE LENGTH	19.25"	BAR GEOMETRY	
B - CHAIN STAY LENGTH	13.2"	G - RISE	8.2"
C - HEAD TUBE ANGLE	75°	H - WIDTH	28"
D - SEAT TUBE ANGLE	71.5°	I - BACKSWEEP	11°
E - BB HEIGHT	11.75"	J - UPSWEEP	2°
F - STANDOVER HEIGHT	8"		

PLEASE NOTE: Final product may vary in appearance.

DARKO-20 INCH

R



RADIO BIKE CO.-MY 2020

DARKO-20 INCH

PLEASE NOTE: Final product may vary in appearance.

RADIO BIKE CO.-MY 2020



R



DARKO-20 INCH

FRAME	crmo top tube & down tube, 1020 hi-ten, removable brake mounts & guides
FORK	RADIO "AM" 1020 hi-ten fork, crmo steerer, tapered legs
BAR	RADIO "DARKO" bar, 1020 hi-ten
GRIPS	RADIO "AM XL" grips
STEM	SALT "PRO" top load stem, 50mm reach
HEADSET	SALT "PRO" int. headset, sealed bearing
GYRO	holes for removable gyro tabs
LEVER	RADIO "AM" alloy brake lever, rear
BRAKES	RADIO "AM" alloy u-brake rear
CRANKS	RADIO "AM" tubular 3pc crank crmo 170mm, 8 spline
BB	mid size, press fit, sealed bearing
PEDALS	RADIO "PRO" nylon/fiberglass pedals
CHAIN	SALT "AM" chain, Z1 type
SPROCKET	RADIO "VISION" steel 25T sprocket
DRIVER	9T cassette driver, sealed bearing
FRONT HUB	RADIO "AM" alloy hub, lb, 3/8"s male axle, 36h
REAR HUB	SALT "AM" cassette hub, fully-sealed, 9t, 14mm axle, 36h
FRONT RIM	SALT "FRACTION" rim, single wall
REAR RIM	SALT "FRACTION" rim, single wall
SEAT	RADIO "CENTURY" fat padded combo seat
SEAT POST	-
SEAT CLAMP	integrated "SLIM" seat clamp
TIRES	SALTPLUS "BURN" tires, 2.35" front & rear
PEGS	-
WEIGHT	tba kg / tba lbs

COLOR matt black gold

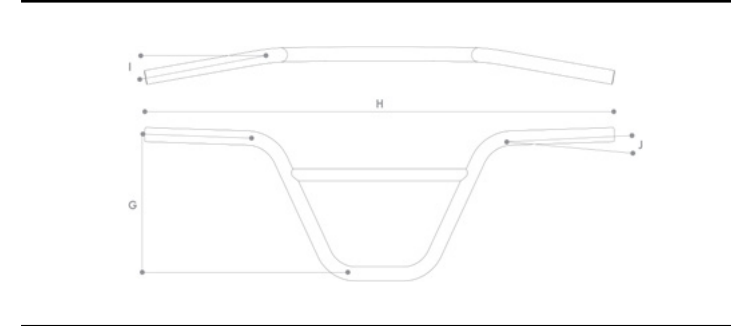
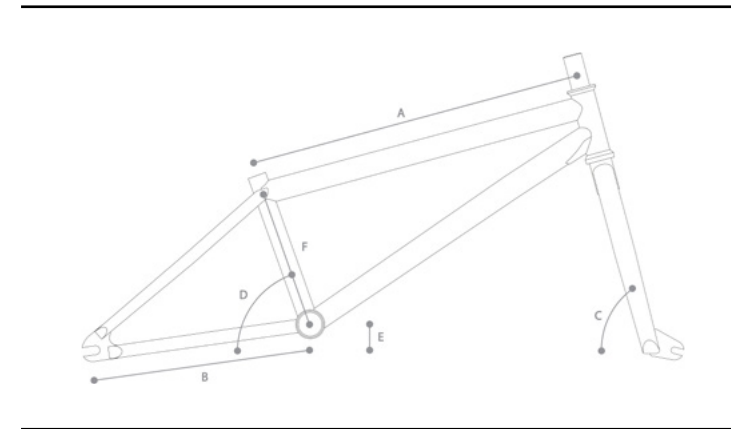

A - TOP TUBE LENGTH	20.5" / 21"	BAR GEOMETRY	
B - CHAIN STAY LENGTH	13.2"	G - RISE	9"
C - HEAD TUBE ANGLE	75°	H - WIDTH	29.5"
D - SEAT TUBE ANGLE	71°	I - BACKSWEEP	12°
E - BB HEIGHT	11.7"	J - UPSWEEP	2°
F - STANDOVER HEIGHT	8.6" / 8.9"		

RADIO BIKE CO.-MY 2020

VALAC-20 INCH

PLEASE NOTE: Final product may vary in appearance.

RADIO BIKE CO.-MY 2020



R



VALAC-20 INCH

FRAME	chainstays crmo, top tube & down tube, 1020 hi-ten, removable brake mounts & guides
FORK	RADIO "PRO" full crmo fork, crmo steerer, 26mm offset
BAR	RADIO "PRO" full crmo bar
GRIPS	RADIO "AM XL" grips
STEM	SALT "ZION" top load stem, 50mm reach
HEADSET	SALT "PRO" int. headset, sealed bearing
GYRO	holes for removable gyro tabs
LEVER	RADIO "AM" alloy brake lever, rear
BRAKES	SALTPLUS "GEO XL" alloy u-brake rear
CRANKS	RADIO "AM" tubular 3pc crank crmo 170mm, 8 spline
BB	mid size, press fit, sealed bearing
PEDALS	RADIO "PRO" nylon/fiberglass pedals
CHAIN	SALT "AM" chain, Z1 type
SPROCKET	RADIO "VISION" steel 25T sprocket
DRIVER	9T cassette driver, sealed bearing
FRONT HUB	SALT "EX" alloy hub, sb, male axle 3/8"s, 36h
REAR HUB	SALT "EX" alloy cassette hub, sb, 9t, 14mm axle, 36h
FRONT RIM	SALTPLUS "BRACE" rim, double wall
REAR RIM	SALTPLUS "BRACE" rim, double wall
SEAT	RADIO "CENTURY" fat padded combo seat
SEAT POST	-
SEAT CLAMP	integrated "SLIM" seat clamp
TIRES	SALTPLUS "BURN" tires, 2.35" front & rear
PEGS	-
WEIGHT	tba kg / tba lbs

COLOR  matt mint/purple fade

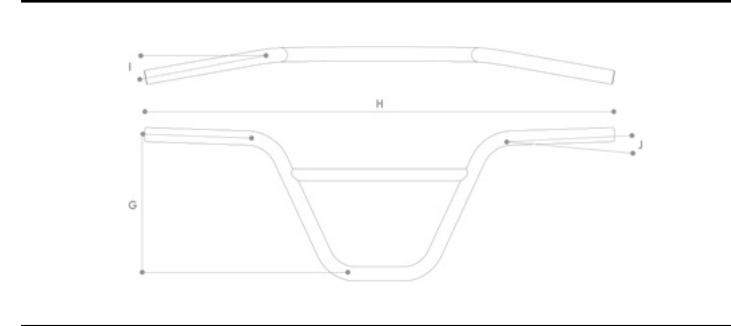
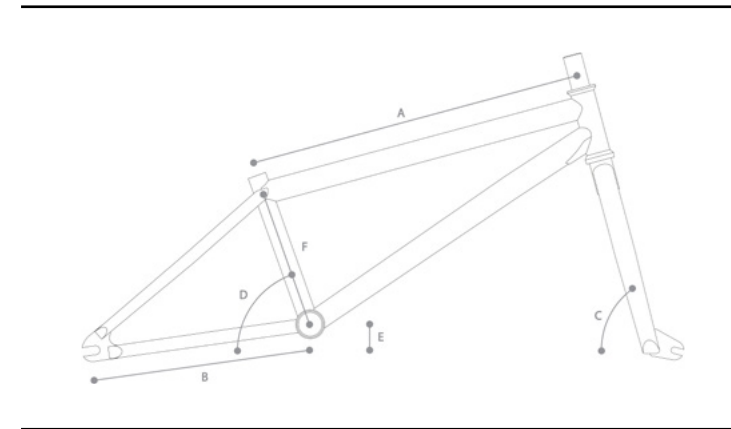

A - TOP TUBE LENGTH	20.75"	BAR GEOMETRY	
B - CHAIN STAY LENGTH	13.2"	G - RISE	9"
C - HEAD TUBE ANGLE	76°	H - WIDTH	29.5"
D - SEAT TUBE ANGLE	71°	I - BACKSWEEP	12°
E - BB HEIGHT	11.8"	J - UPSWEEP	2°
F - STANDOVER HEIGHT	9"		

RADIO BIKE CO. - MY 2020

ASTRON-20 INCH

PLEASE NOTE: Final product may vary in appearance.

RADIO BIKE CO.-MY 2020



R



ASTRON-20 INCH

FRAME	full crmo, removable brake mounts & guides
FORK	RADIO "PRO" full crmo fork, crmo steerer, 26mm offset
BAR	RADIO "PRO" full crmo bar
GRIPS	SALT "EX" grips, flangeless
STEM	SALT "COMP" top load stem, 50mm reach
HEADSET	SALT "PRO" int. headset, sealed bearing
GYRO	SALT "AM" rotor with SALT "AM" rotor cables
LEVER	SALT "MOTO" alloy brake lever, rear
BRAKES	SALTPLUS "GEO XL" alloy u-brake rear
CRANKS	RADIO "AM" tubular 3pc crank crmo 170mm, 8 spline
BB	mid size, press fit, sealed bearing
PEDALS	RADIO "SLIM" nylon/fiberglass pedals
CHAIN	SALT "AM" chain, Z1 type
SPROCKET	RADIO "VISION" steel 25T sprocket
DRIVER	9T cassette driver, sealed bearing
FRONT HUB	RADIO "PRO" alloy hub, sb, 3/8"s female axle, 36h
REAR HUB	RADIO "PRO" alloy cassette hub, sb, 9t, 14mm hollow axle, 36h
FRONT RIM	SALTPLUS "BRACE" rim, double wall
REAR RIM	SALTPLUS "BRACE" rim, double wall
SEAT	RADIO "CENTURY" slim padded combo seat
SEAT POST	-
SEAT CLAMP	integrated "SLIM" seat clamp
TIRES	SALTPLUS "BURN" tires, 2.30" front & rear
PEGS	-
WEIGHT	tba kg / tba lbs

COLOR metallic teal

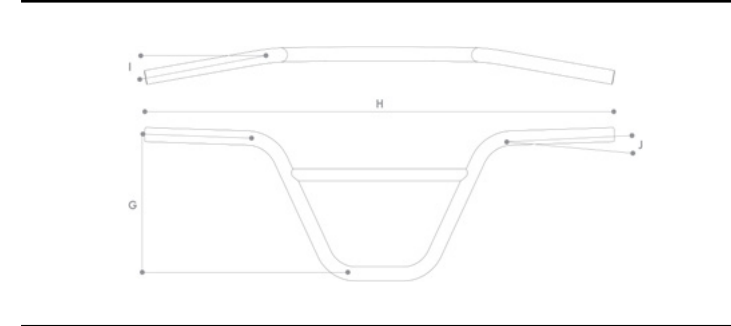
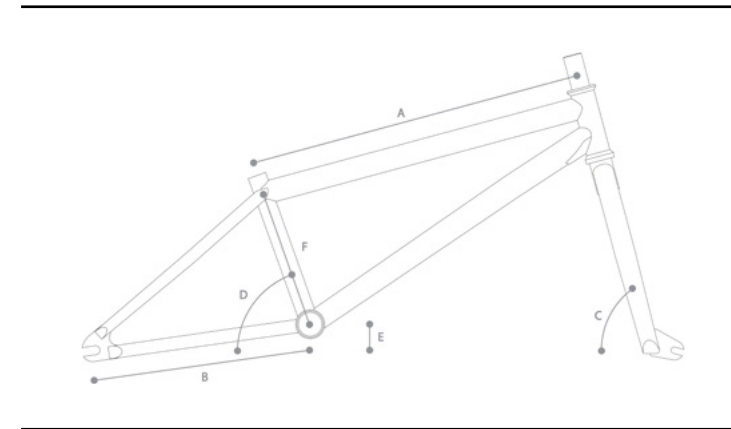

A - TOP TUBE LENGTH	20.6"	BAR GEOMETRY	
B - CHAIN STAY LENGTH	13.2"	G - RISE	9"
C - HEAD TUBE ANGLE	76°	H - WIDTH	29.5"
D - SEAT TUBE ANGLE	71°	I - BACKSWEEP	12°
E - BB HEIGHT	11.6"	J - UPSWEEP	2°
F - STANDOVER HEIGHT	9"		

RADIO BIKE CO.-MY 2020

COMRAD-20 INCH

PLEASE NOTE: Final product may vary in appearance.

RADIO BIKE CO.-MY 2020



R



COMRAD-20 INCH

FRAME	full crmo, removable brake mounts & guides
FORK	RADIO "PRO" full crmo fork, crmo steerer, 26mm offset
BAR	SALTPLUS "HQ" full crmo 4pc bar
GRIPS	RADIO "FREQUENCY XL" grips, flangeless
STEM	RADIO "AXIS" top load stem, 50mm reach
HEADSET	SALT "PRO" int. headset, sealed bearing
GYRO	holes for removable gyro tabs
LEVER	SALT "MOTO" alloy brake lever, rear
BRAKES	ÉCLAT "TALON" alloy u-brake rear
CRANKS	RADIO "PRO" tubular 3pc crank crmo 170mm, 8 spline
BB	mid size, press fit, sealed bearing
PEDALS	RADIO "PRO" nylon/fiberglass pedals
CHAIN	SALTPLUS "WARLOCK" halflink chain
SPROCKET	RADIO "47" Leon Hoppe signature sprocket guard, 25T, 6061-T6
DRIVER	9T freecoaster driver, sealed bearing, RSD
FRONT HUB	SALT "EX" alloy hub, sb, 3/8" female axle, 36h, w/x2 SALTPLUS "PRO" nylon hubguards
REAR HUB	SALTPLUS "VERTEX" alloy freecoaster hub, sb, 9t, 14mm hollow axle, 36h, w/x2 SALTPLUS "PRO" nylon hubguards
FRONT RIM	SALTPLUS "BRACE" rim, double wall
REAR RIM	SALTPLUS "BRACE" rim, double wall
SEAT	RADIO "CENTURY" fat padded combo seat
SEAT POST	-
SEAT CLAMP	integrated "SLIM" seat clamp
TIRES	SALTPLUS "BURN" tires, 2.35" front & rear
PEGS	-
WEIGHT	tba kg / tba lbs

COLOR matt black

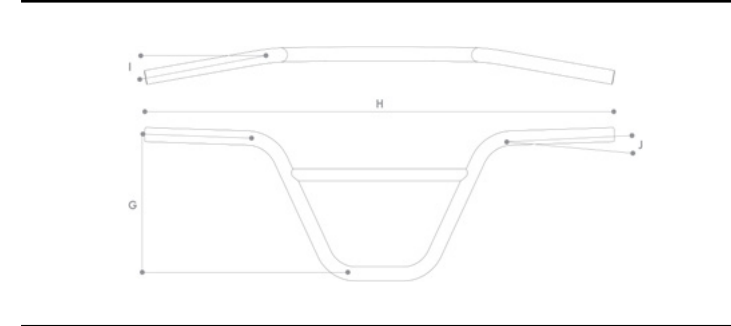
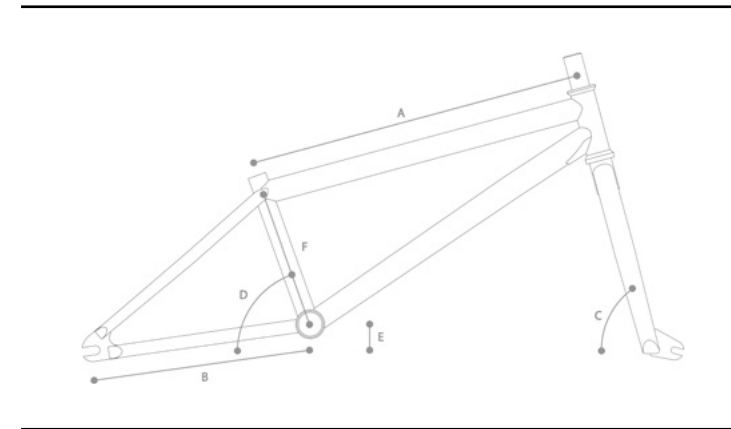

A - TOP TUBE LENGTH	21"	BAR GEOMETRY	
B - CHAIN STAY LENGTH	13.2"	G - RISE	9"
C - HEAD TUBE ANGLE	75.5°	H - WIDTH	29.1"
D - SEAT TUBE ANGLE	71°	I - BACKSWEEP	11°
E - BB HEIGHT	11.7"	J - UPSWEEP	3°
F - STANDOVER HEIGHT	9.25"		

RADIO BIKE CO.-MY 2020

FIEND-26 INCH

PLEASE NOTE: Final product may vary in appearance.

RADIO BIKE CO.-MY 2020



R



FIEND-26 INCH

FRAME	6061-T6 alloy, tapered head tube
FORK	RST "OMEGA T26" 100mm travel
BAR	RADIO "ASURA" bar, 6061-T6 alloy, 31.8mm
GRIPS	RADIO "FREQUENCY XL" grips, flangeless
STEM	RADIO "DJ" front load stem, alloy, 40mm reach
HEADSET	FSA "NO.57E" int. a-headset, 1-1/8"-1.5"
GYRO	-
LEVER	TEKTRO "RS-360A", front & rear
BRAKES	TEKTRO "ARIES" mechanical disc brake, 160mm rotor, front & rear
CRANKS	RADIO "PRO" forged alloy 2pc crank 170mm, 24mm spindle
BB	RADIO "BSA24" sealed bearing
PEDALS	RADIO "SLIM" nylon/fiberglass pedals
CHAIN	KMC "X8" chain
SPROCKET	RADIO "AM" steel sprocket 32T
DRIVER	SUN RACE 12-32T, 8 speed
FRONT HUB	RADIO "AM-DJ" disc hub, alloy, sealed, QR, 32h
REAR HUB	RADIO "AM-DJ" disc cassette hub, alloy, sealed, QR, 32h
FRONT RIM	RADIO "DB30" rim, double wall
REAR RIM	RADIO "DB30" rim, double wall
SEAT	RADIO "DJ" medium padded combo seat
SEAT POST	-
SEAT CLAMP	RADIO "QUICK RELEASE" alloy seat clamp
TIRES	RADIO "ROOKIE" tires, 2.2" front & rear
PEGS	-
WEIGHT	tba kg / tba lbs

COLOR metallic red

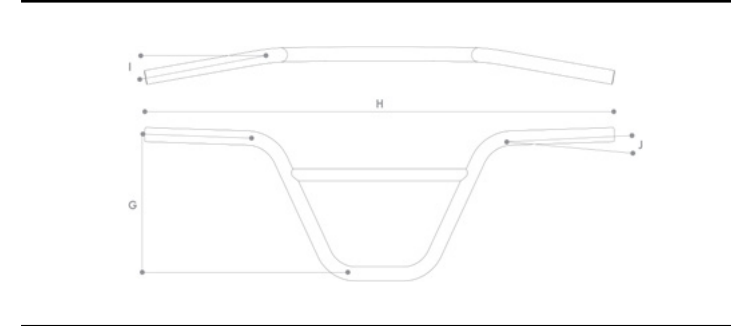
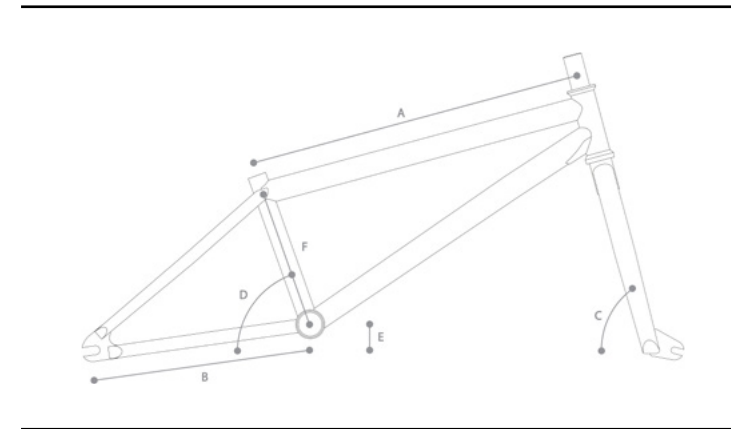

A - TOP TUBE LENGTH	22.3"	BAR GEOMETRY	
B - CHAIN STAY LENGTH	15.8"	G - RISE	50mm
C - HEAD TUBE ANGLE	70°	H - WIDTH	740mm
D - SEAT TUBE ANGLE	75°	I - BACKSWEEP	8°
E - BB HEIGHT	25mm drop	J - UPSWEEP	3°
F - STANDOVER HEIGHT	11"		

RADIO BIKE CO.-MY 2020

GRIFFIN-26 INCH

PLEASE NOTE: Final product may vary in appearance.

RADIO BIKE CO.-MY 2020



R



GRIFFIN-26 INCH

FRAME	6061-T6 alloy, tapered head tube, forged yoke
FORK	MANITOU "CIRCUS SPORT" 100mm travel
BAR	RADIO "GRIFFIN" bar, 6061-T6 alloy, 35mm
GRIPS	RADIO "FREQUENCY XL" grips, flangeless
STEM	RACE FACE "CHESTER 35" front load stem, alloy, 40mm reach
HEADSET	FSA "NO.42/ACB-A" integrated a-headset, 1-1/8"-1.5"
GYRO	-
LEVER	TEKTRO "RS-360A" front, SRAM "DB-LVL-A1" rear
BRAKES	TEKTRO "ARIES" mechanical disc brake front, SRAM "DB-LVL-A1" hydraulic disc brake rear, 160mm rotor
CRANKS	SALTPLUS "ULTRA" square profile 3pc "TSS" crank crmo 170mm, 8 spline
BB	RADIO "BSA19" sealed bearing
PEDALS	RADIO "SLIM" nylon/fiberglass pedals
CHAIN	SALT "AM" chain, Z1 type
SPROCKET	SALT "GATEWAY" alloy 25T sprocket
DRIVER	10T cassette driver, sealed bearing
FRONT HUB	RADIO "PRO-DJ" disc hub, sealed, 15mm alloy through axle, 32h
REAR HUB	RADIO "PRO-DJ" disc hub, sealed, 3/8"s crmo axle, 32h
FRONT RIM	RADIO "DB32" rim, double wall
REAR RIM	RADIO "DB32" rim, double wall
SEAT	RADIO "DJ" medium padded combo seat
SEAT POST	-
SEAT CLAMP	RADIO "SLIM" alloy seat clamp
TIRES	MAXXIS "DTH" tires, 2.3" front & rear
PEGS	-
WEIGHT	tba kg / tba lbs

COLOR metallic blue

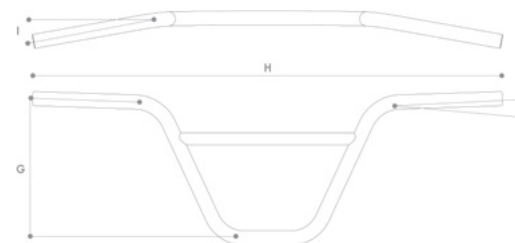
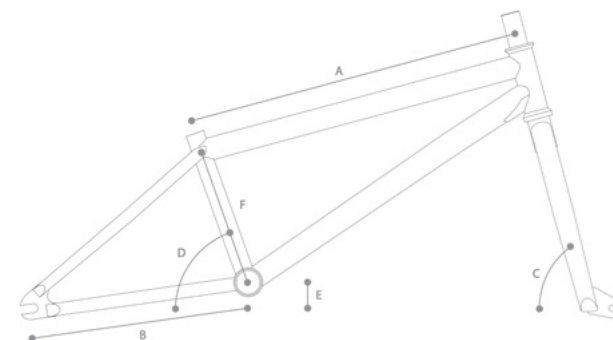

A - TOP TUBE LENGTH	22.6"	BAR GEOMETRY	
B - CHAIN STAY LENGTH	15"	G - RISE	50mm
C - HEAD TUBE ANGLE	69°	H - WIDTH	760mm
D - SEAT TUBE ANGLE	72°	I - BACKSWEEP	8°
E - BB HEIGHT	20mm drop	J - UPSWEEP	3°
F - STANDOVER HEIGHT	11"		

RADIO BIKE CO.-MY 2020

GRIFFIN PRO-26 INCH

PLEASE NOTE: Final product may vary in appearance.

RADIO BIKE CO.-MY 2020



R



GRIFFIN PRO-26 INCH

FRAME	6061-T6 hydroformed & butted alloy, tapered head tube, forged yoke
FORK	MANITOU "CIRCUS EXPERT" 100mm travel
BAR	RADIO "GRIFFIN" bar, 6061-T6 alloy, 35mm
GRIPS	RADIO "FREQUENCY XL" grips, flangeless
STEM	RACE FACE "CHESTER 35" front load stem, alloy, 40mm reach
HEADSET	FSA "NO.42/ACB-A" integrated a-headset, 1-1/8"-1.5"
GYRO	-
LEVER	TEKTRO "RS-360A" front, SRAM "DB-LVL-A1" rear
BRAKES	TEKTRO "ARIES" mechanical disc brake front, SRAM "DB-LVL-A1" hydraulic disc brake rear, 160mm rotor
CRANKS	RACE FACE "AEFFECT" crank alloy, 170mm
BB	RACE FACE "AEFFECT" BSA, sealed bearing
PEDALS	RADIO "SLIM" nylon/fiberglass pedals
CHAIN	SALT "AM" chain, Z1 type
SPROCKET	RACE FACE "AEFFECT" alloy 28T sprocket
DRIVER	10T cassette driver, sealed bearing
FRONT HUB	RADIO "PRO-DJ" disc hub, sealed, 15mm alloy through axle, 32h
REAR HUB	RADIO "PRO-DJ" disc hub, sealed, 3/8"s crmo axle, 32h
FRONT RIM	RADIO "DB-T25" rim, double wall, sleeved
REAR RIM	RADIO "DB-T25" rim, double wall, sleeved
SEAT	RADIO "DJ" medium padded combo seat
SEAT POST	-
SEAT CLAMP	RADIO "SLIM" alloy seat clamp
TIRES	MAXXIS "DTH" tires, 2.3" front & rear
PEGS	-
WEIGHT	tba kg / tba lbs

COLOR black

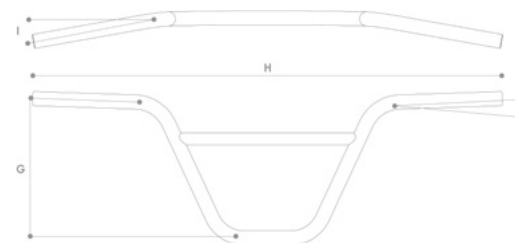
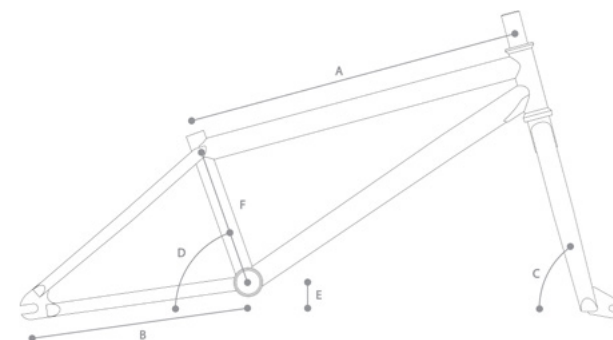

A - TOP TUBE LENGTH	22.8"	BAR GEOMETRY	
B - CHAIN STAY LENGTH	15"	G - RISE	50mm
C - HEAD TUBE ANGLE	70°	H - WIDTH	760mm
D - SEAT TUBE ANGLE	70°	I - BACKSWEEP	8°
E - BB HEIGHT	14mm drop	J - UPSWEEP	3°
F - STANDOVER HEIGHT	10.2"		

RADIO BIKE CO.-MY 2020

SIREN-26 INCH

PLEASE NOTE: Final product may vary in appearance.

RADIO BIKE CO.-MY 2020



R



SIREN-26 INCH

FRAME	6061-T6 hydroformed & butted alloy, tapered head tube, 100mm travel
FORK	ROCK SHOX "PIKE DJ" 100mm travel/REAR SHOCK: ROCK SHOX "RS-MONARCH R" 190x51
BAR	RADIO "GRIFFIN" bar, 6061-T6 alloy, 35mm
GRIPS	RADIO "FREQUENCY XL" grips, flangeless
STEM	RACE FACE "CHESTER 35" front load stem, alloy, 40mm reach
HEADSET	FSA "NO.42/ACB-A" integrated a-headset, 1-1/8"-1.5"
GYRO	-
LEVER	TEKTRO "RS-360A" front, SRAM "DB-LVL-A1" rear
BRAKES	TEKTRO "ARIES" mechanical disc brake front, SRAM "DB-LVL-A1" hydraulic disc brake rear, 160mm rotor
CRANKS	RACE FACE "AEFFECT" crank alloy, 170mm
BB	RACE FACE "AEFFECT" BSA, sealed bearing
PEDALS	RADIO "SLIM" nylon/fiberglass pedals
CHAIN	SALT "AM" chain, Z1 type
SPROCKET	RACE FACE "AEFFECT" alloy 28T sprocket
DRIVER	10T cassette driver, sealed bearing
FRONT HUB	RADIO "PRO-DJ" disc hub, sealed, 15mm alloy through axle, 32h
REAR HUB	RADIO "PRO-DJ" disc hub, sealed, 3/8"s crmo axle, 32h
FRONT RIM	RADIO "DB-T25" rim, double wall, sleeved
REAR RIM	RADIO "DB-T25" rim, double wall, sleeved
SEAT	RADIO "PIVOTAL" fat padded seat
SEAT POST	RADIO "PIVOTAL" seat post, alloy
SEAT CLAMP	RADIO "SLIM" alloy seat clamp
TIRES	MAXXIS "DTH" tires, 2.3" front & rear
PEGS	-
WEIGHT	tba kg / tba lbs

COLOR matt black

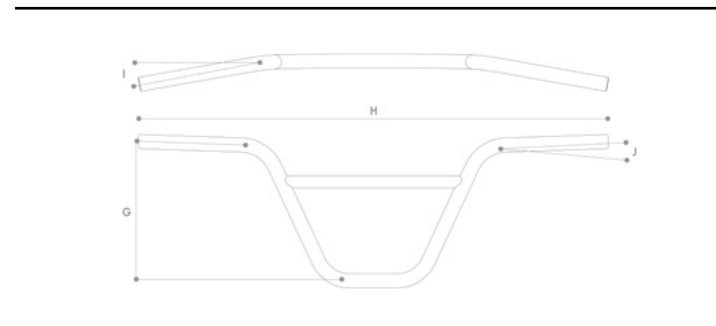
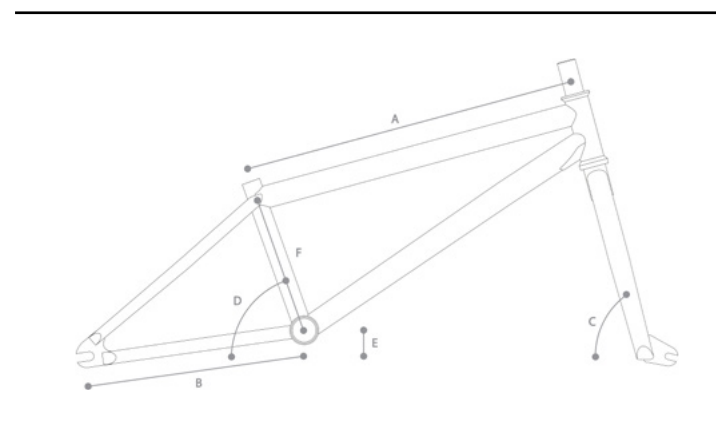

A - TOP TUBE LENGTH	* 22.8"	BAR GEOMETRY	
B - CHAIN STAY LENGTH	16"	G - RISE	50mm
C - HEAD TUBE ANGLE	70°	H - WIDTH	760mm
D - SEAT TUBE ANGLE	75°	I - BACKSWEEP	8°
E - BB HEIGHT	3mm rise	J - UPSWEEP	3°
F - SEAT TUBE LENGTH	305mm		

* effective length

RADIO BIKE CO.-MY 2020

ASURA-26 INCH

PLEASE NOTE: Final product may vary in appearance.

RADIO BIKE CO.-MY 2020



R



ASURA-26 INCH

FRAME	crmo top tube & down tube, 1020 hi-ten
FORK	RST "DIRT RA" 100mm travel
BAR	RADIO "ASURA" bar, 6061-T6 alloy, 31.8mm
GRIPS	RADIO "FREQUENCY XL" grips, flangeless
STEM	RADIO "ASURA" front load stem, alloy, 40mm reach
HEADSET	FSA "NO.28" a-headset
GYRO	-
LEVER	TEKTRO "RS-360A", front & rear
BRAKES	TEKTRO "ARIES" mechanical disc brake, 160mm rotor, front & rear
CRANKS	RADIO "PRO" tubular 3pc crank crmo 170mm, 8 spline
BB	mid size, press fit, sealed bearing
PEDALS	RADIO "SLIM" nylon/fiberglass pedals
CHAIN	SALT "AM" chain, Z1 type
SPROCKET	RADIO "ROOKIE" steel 30T sprocket
DRIVER	ATA 10T crmo freewheel
FRONT HUB	RADIO "ROOKIE-DJ" disc hub, alloy, loose ball, 3/8"s crmo axle, 32h
REAR HUB	RADIO "ROOKIE-DJ" disc hub, alloy, sealed, 3/8"s crmo axle, 32h
FRONT RIM	RADIO "DB32" rim, double wall
REAR RIM	RADIO "DB32" rim, double wall
SEAT	RADIO "DJ" medium padded combo seat
SEAT POST	-
SEAT CLAMP	RADIO "SLIM" alloy seat clamp
TIRES	KENDA "SMALL BLOCK EIGHT" tires, 2.1" front, 1.95" rear
PEGS	-
WEIGHT	tba kg / tba lbs

COLOR  metallic purple

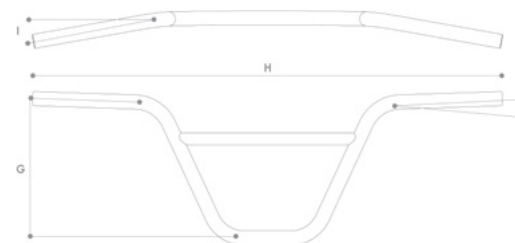
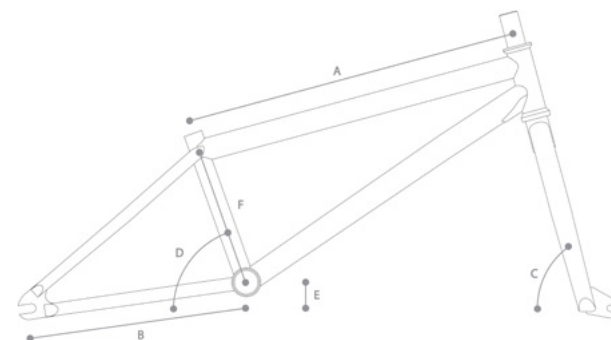

A - TOP TUBE LENGTH	22.7"	BAR GEOMETRY	
B - CHAIN STAY LENGTH	15.5"	G - RISE	50mm
C - HEAD TUBE ANGLE	70°	H - WIDTH	740mm
D - SEAT TUBE ANGLE	72.5°	I - BACKSWEEP	8°
E - BB HEIGHT	4mm drop	J - UPSWEEP	3°
F - STANDOVER HEIGHT	10.5"		

RADIO BIKE CO.-MY 2020

ASURA PRO-26 INCH

PLEASE NOTE: Final product may vary in appearance.

RADIO BIKE CO.-MY 2020



R



ASURA PRO-26 INCH

FRAME	full 4130 crmo
FORK	MANITOU "CIRCUS SPORT" 100mm travel
BAR	RADIO "ASURA" bar, 6061-T6 alloy, 31.8mm
GRIPS	RADIO "FREQUENCY XL" grips, flangeless
STEM	RADIO "ASURA" front load stem, alloy, 40mm reach
HEADSET	SALT "PRO" int. headset, sealed bearing
GYRO	-
LEVER	TEKTRO "RS-360A" front, SRAM "DB-LVL-A1" rear
BRAKES	TEKTRO "ARIES" mechanical disc brake front, SRAM "DB-LVL-A1" hydraulic disc brake rear, 160mm rotor
CRANKS	RADIO "PRO" tubular 3pc crank crmo 170mm, 8 spline
BB	mid size, press fit, sealed bearing
PEDALS	RADIO "SLIM" nylon/fiberglass pedals
CHAIN	SALT "AM" chain, Z1 type
SPROCKET	RADIO "VISION" alloy 25T sprocket
DRIVER	10T cassette driver, sealed bearing
FRONT HUB	RADIO "PRO-DJ" disc hub, sealed, 3/8"s crmo axle, 32h
REAR HUB	RADIO "PRO-DJ" disc hub, sealed, 3/8"s crmo axle, 32h
FRONT RIM	RADIO "DB32" rim, double wall
REAR RIM	RADIO "DB32" rim, double wall
SEAT	RADIO "DJ" medium padded combo seat
SEAT POST	-
SEAT CLAMP	RADIO "SLIM" alloy seat clamp
TIRES	KENDA "SMALL BLOCK EIGHT" tires, 2.1" front, 1.95" rear
PEGS	-
WEIGHT	tba kg / tba lbs

COLOR  c.p.

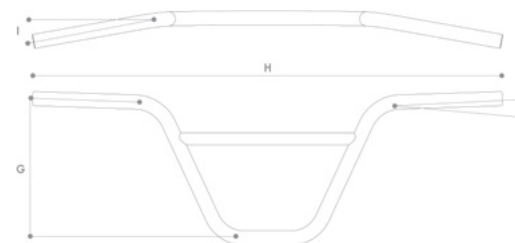
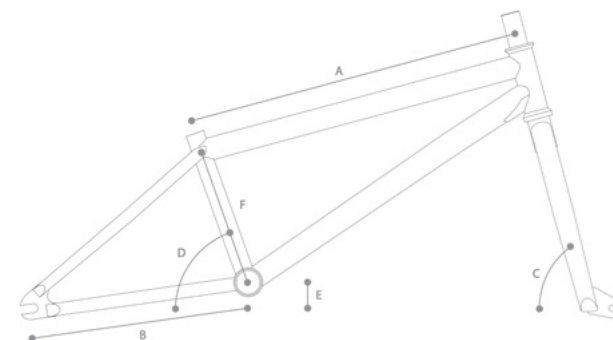

A - TOP TUBE LENGTH	22.7"	BAR GEOMETRY	
B - CHAIN STAY LENGTH	15"	G - RISE	50mm
C - HEAD TUBE ANGLE	70°	H - WIDTH	740mm
D - SEAT TUBE ANGLE	72.5°	I - BACKSWEEP	8°
E - BB HEIGHT	4mm drop	J - UPSWEEP	3°
F - STANDOVER HEIGHT	10.5"		

RADIO BIKE CO.-MY 2020

LEGION-26 INCH

PLEASE NOTE: Final product may vary in appearance.

RADIO BIKE CO.-MY 2020



R



LEGION-26 INCH

FRAME	6061-T6 alloy
FORK	RADIO "LEGION26" full crmo fork, 30mm offset
BAR	RADIO "LEGION" full 4130 crmo bar
GRIPS	RADIO "FREQUENCY XL" grips, flangeless
STEM	SALT "COMP" top load stem, 50mm reach
HEADSET	FSA "NO.28" a-headset
GYRO	-
LEVER	TEKTRO "RS-360A", front & rear
BRAKES	TEKTRO "837AL" alloy v-brake, front, TEKTRO "ARIES" mechanical disc brake, 160mm rotor rear
CRANKS	RADIO "PRO" tubular 3pc crank crmo 175mm, 8 spline
BB	RADIO "BSA19" sealed bearing
PEDALS	RADIO "PRO" nylon/fiberglass pedals
CHAIN	SALT "AM" chain, Z1 type
SPROCKET	RADIO "LEGION" alloy 26T sprocket
DRIVER	12T cassette driver, sealed bearing
FRONT HUB	RADIO "PRO" alloy hub, sealed, 3/8"s female axle, 36h
REAR HUB	RADIO "PRO" disc hub, sealed, 12T, 3/8"s hollow axle, 36h
FRONT RIM	RADIO "DB35" rim, double wall
REAR RIM	RADIO "DB35" rim, double wall
SEAT	RADIO "LEGION" railed seat
SEAT POST	RADIO "SP228" micro-adjust seat post alloy
SEAT CLAMP	RADIO "QUICK RELEASE" alloy seat clamp
TIRES	RADIO "LEGION26" tires, 2.2" front & rear
PEGS	-
WEIGHT	tba kg / tba lbs

COLOR matt galactic purple

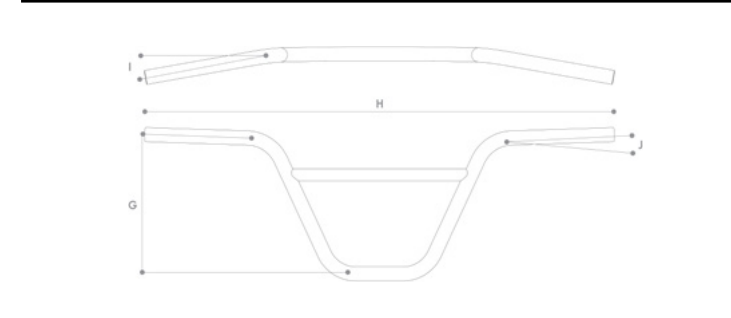
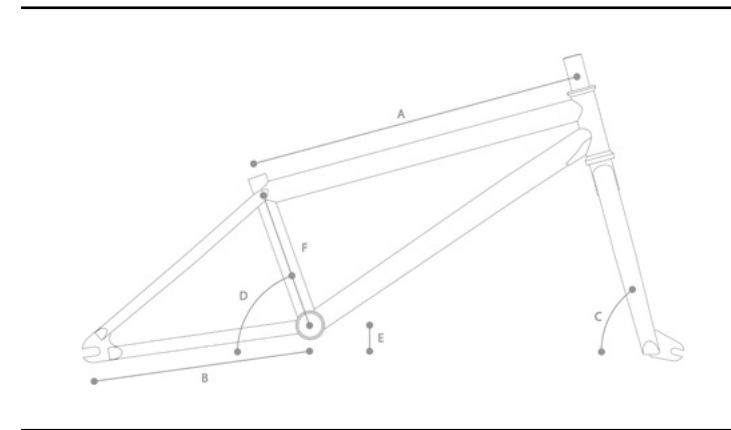

A - TOP TUBE LENGTH	22"	BAR GEOMETRY	
B - CHAIN STAY LENGTH	16.7"	G - RISE	6.1"
C - HEAD TUBE ANGLE	71°	H - WIDTH	30"
D - SEAT TUBE ANGLE	71.5°	I - BACKSWEEP	10°
E - BB HEIGHT	33mm drop	J - UPSWEEP	3°
F - STANDOVER HEIGHT	12.8"		

RADIO BIKE CO.-MY 2020

LEGION-29 INCH

PLEASE NOTE: Final product may vary in appearance.

RADIO BIKE CO.-MY 2020



R



LEGION-29 INCH

FRAME	6061-T6 alloy
FORK	RADIO "LEGION29" full crmo fork, 30mm offset
BAR	RADIO "LEGION" full 4130 crmo bar
GRIPS	RADIO "FREQUENCY XL" grips, flangeless
STEM	SALT "COMP" top load stem, 50mm reach
HEADSET	FSA "NO.28" a-headset
GYRO	-
LEVER	TEKTRO "RS-360A", front & rear
BRAKES	TEKTRO "837AL" alloy v-brake, front, TEKTRO "ARIES" mechanical disc brake, 160mm rotor rear
CRANKS	RADIO "PRO" tubular 3pc crank crmo 175mm, 8 spline
BB	RADIO "BSA19" sealed bearing
PEDALS	RADIO "PRO" nylon/fiberglass pedals
CHAIN	SALT "AM" chain, Z1 type
SPROCKET	RADIO "LEGION" alloy 28T sprocket
DRIVER	12T cassette driver, sealed bearing
FRONT HUB	RADIO "PRO" alloy hub, sealed, 3/8"s female axle, 36h
REAR HUB	RADIO "PRO" disc hub, sealed, 12T, 3/8"s hollow axle, 36h
FRONT RIM	RADIO "DB35" rim, double wall
REAR RIM	RADIO "DB35" rim, double wall
SEAT	RADIO "LEGION" railed seat
SEAT POST	RADIO "SP228" micro-adjust seat post alloy
SEAT CLAMP	RADIO "QUICK RELEASE" alloy seat clamp
TIRES	RADIO "LEGION29" tires, 2.3" front & rear
PEGS	-
WEIGHT	tba kg / tba lbs

COLOR black

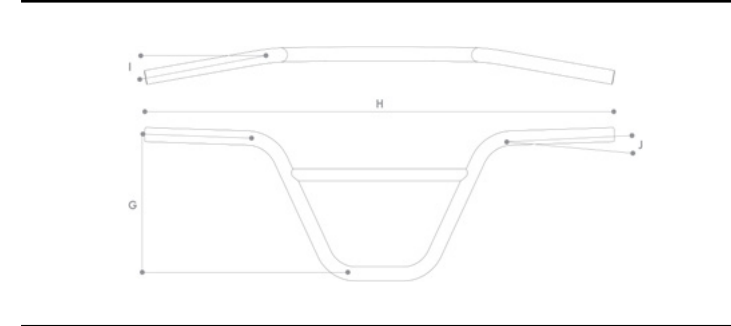
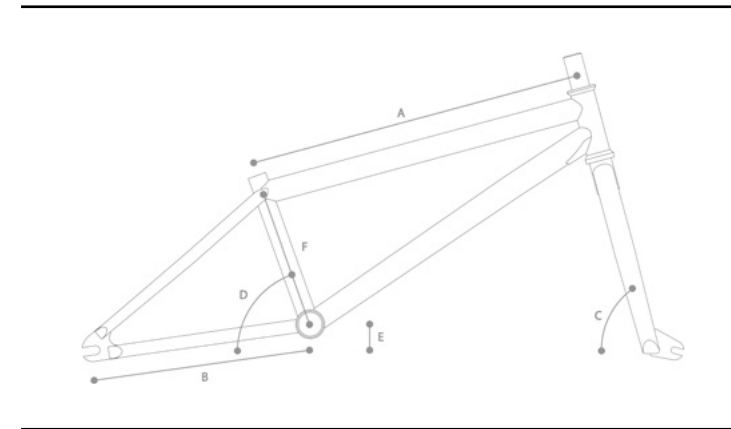

A - TOP TUBE LENGTH	23.5"	BAR GEOMETRY	
B - CHAIN STAY LENGTH	18"	G - RISE	6.1"
C - HEAD TUBE ANGLE	71°	H - WIDTH	30"
D - SEAT TUBE ANGLE	71°	I - BACKSWEEP	10°
E - BB HEIGHT	65mm drop	J - UPSWEEP	3°
F - SEAT TUBE LENGTH	430mm		

RADIO BIKE CO.-MY 2020

CEPTOR-26 INCH

PLEASE NOTE: Final product may vary in appearance.

RADIO BIKE CO.-MY 2020



R



CEPTOR-26 INCH

FRAME	full crmo, oval & tapered chain stays
FORK	RADIO "CEPTOR" full crmo fork, 24mm offset
BAR	RADIO "CEPTOR" full 4130 crmo bar
GRIPS	RADIO "FREQUENCY XL" grips, flangeless
STEM	SALT "PRO" top load stem, 50mm reach
HEADSET	SALT "PRO" int. headset, sealed bearing
GYRO	-
LEVER	RADIO "AM" alloy brake lever
BRAKES	SALTPLUS "GEO XL" alloy u-brake rear
CRANKS	RADIO "PRO" tubular 3pc crank crmo 175mm, 8 spline
BB	mid size, press fit, sealed bearing
PEDALS	RADIO "SLIM" nylon/fiberglass pedals
CHAIN	SALTPLUS "WARLOCK" halflink chain
SPROCKET	RADIO "PRO" 6061-T6 alloy 26T sprocket
DRIVER	10T 1-piece cassette driver, sealed bearing
FRONT HUB	RADIO "PRO" alloy hub, sb, 3/8"s female axle, 36h
REAR HUB	RADIO "PRO" alloy cassette hub, sb, 10t, 14mm hollow axle, 36h
FRONT RIM	RADIO "FR32" rim, double wall
REAR RIM	RADIO "FR32" rim, double wall
SEAT	RADIO "CENTURY" fat padded tripod seat
SEAT POST	RADIO "TRIPOD" alloy post
SEAT CLAMP	integrated "SLIM" seat clamp
TIRES	BOMBTRACK tires, "HELIX V2" 2.3" front & rear
PEGS	-
WEIGHT	13.58kg / 29.94lbs

COLOR matt olive patina

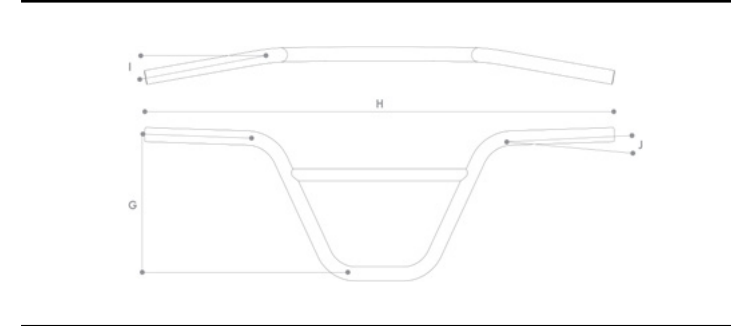
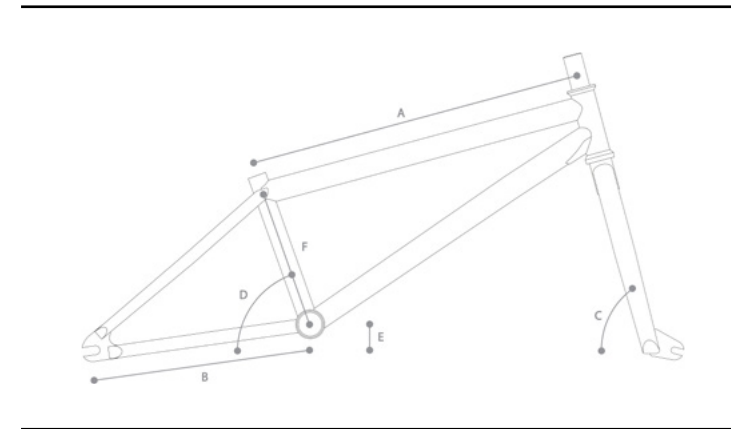

A - TOP TUBE LENGTH	22.7"	BAR GEOMETRY	
B - CHAIN STAY LENGTH	15.7"	G - RISE	5.5"
C - HEAD TUBE ANGLE	75°	H - WIDTH	29"
D - SEAT TUBE ANGLE	71°	I - BACKSWEEP	10°
E - BB HEIGHT	10mm drop	J - UPSWEEP	4°
F - STANDOVER HEIGHT	11.6"		

RADIO BIKE CO.-MY 2020

DIVIDE-700^C

PLEASE NOTE: Final product may vary in appearance.

RADIO BIKE CO.-MY 2020



R



DIVIDE-700 ^C

FRAME	down tube, seat tube crmo, 1020 hi-ten
FORK	RADIO "DIVIDE" full crmo fork, 30mm offset
BAR	RADIO "DIVIDE" bar, 6061-T6 alloy, 31.8mm
GRIPS	RADIO "FREQUENCY XL" grips, flangeless
STEM	RADIO "DIVIDE" front load stem, alloy, 45mm reach
HEADSET	SALT "PRO" int. headset, sealed bearing
GYRO	-
LEVER	RADIO "AM" alloy v-brake levers, front & rear
BRAKES	TEKTRO "RX6" v-brakes, front & rear
CRANKS	RADIO "AM" TSS tubular 3pc crank crmo, 8 spline
BB	mid size, press fit, sealed bearing
PEDALS	RADIO "SLIM" nylon/fiberglass pedals
CHAIN	SALTPLUS "WARLOCK" halflink chain
SPROCKET	SALTPLUS "TRIDENT" 6061-T6 alloy 26T sprocket
DRIVER	10T cassette driver, sealed bearing
FRONT HUB	RADIO "PRO" alloy hub, sb, 3/8"s female axle, 36h
REAR HUB	RADIO "PRO" alloy cassette hub, sb, 10t, 14mm hollow axle, 36h
FRONT RIM	RADIO "CX26" rim, double wall
REAR RIM	RADIO "CX26" rim, double wall
SEAT	RADIO "DIVIDE" slim padded, railed seat
SEAT POST	RADIO "620" micro-adjust seat post alloy
SEAT CLAMP	RADIO "SLIM" alloy seat clamp
TIRES	BOMBTRACK tires, "HELIX V2" 45c front & rear
PEGS	-
WEIGHT	12.86kg / 28.37lbs

COLOR matt black

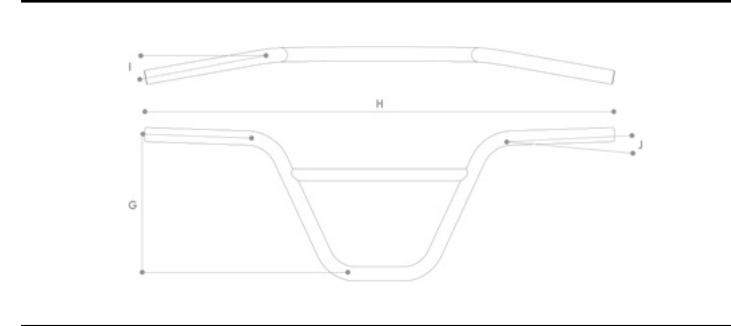
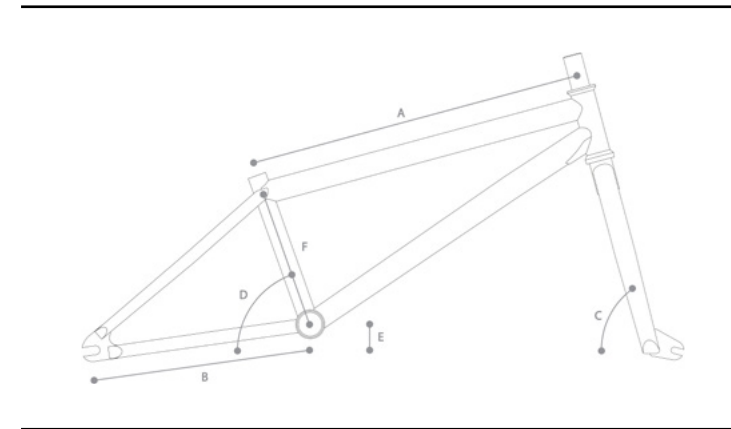

A - TOP TUBE LENGTH	515mm (S) 550mm (M) 595mm (L)	BAR GEOMETRY	
B - CHAIN STAY LENGTH	16"	G - RISE	2.2"
C - HEAD TUBE ANGLE	73°	H - WIDTH	26"
D - SEAT TUBE ANGLE	74°	I - BACKSWEEP	8°
E - BB HEIGHT	55mm drop	J - UPSWEEP	5°
F - SEAT TUBE LENGTH	480mm (S) 520mm (M) 550mm (L)		

RADIO BIKE CO. - MY 2020

WE MAKE THINGS GmbH
Richard-Byrd-Str. 12
D-50829 Cologne / Germany
Tel: +49 (0)221-500057-20
Fax: +49 (0)221-500057-29
Email: mail@radiobikes.com

RADIOTM



RADICTM

R A C E L I N E

20

COMPLETE
BIKES

RADIO RACELINE

combines over 20 years of experience of creating BMX bikes together with input from some of the world's best racers and industry players to create a revolutionary and all-encompassing line up of bikes built to take you to the finish line, unlike anything else.

Tested on the track and designed in conjunction with a team with BMX race knowledge spanning 3 decades, RADIO RACELINE enters the market with an incredibly well thought out and powerful line of pure bred race machines.

With a full line of bikes in all sizes from MINI all the way to PRO XL, the range kicks off with the entry level COBALT line that packs an enormous amount of technology and features into what essentially will be a rider's first race bike. Even from day one, we believe in giving the rider a bike which will allow them every chance to rapidly climb the ranks and on to the podium. The series then progresses to the mid-level XENON line, where the bikes themselves have been created with incredibly stiff and responsive frames with specific incremental spec and geometry changes, giving all riders the "perfect" feel no matter their age, size or ability.

Building off a hugely successful first year, the 2020 line of bikes sees the addition of exciting new colourways on both our COBALT and the XENON lines, as well as the brand new HELIUM Cruiser complete bike for all the 24" veterans out there wanting the perfect setup to take straight to the track and start getting results.

The logo for Radio Raceline features the word "RADIO" in a large, bold, italicized sans-serif font. Below it, the word "RACELINE" is written in a smaller, spaced-out, all-caps sans-serif font. A small trademark symbol (TM) is located at the top right of the "E" in "RADIO".

RADIOTM
R A C E L I N E



courtesy of moorelarge.co.uk

From our entry level bikes all the way through to our aftermarket frames, all RADIO products are designed to feel comfortable, stiff and fast, exactly how a race bike should. You'll find no gimmicks on any of our bikes, no "goofy" tubing shapes or unnecessary features. Our bikes have been built from the ground up with race proven geometry and technology combined with clean, functional aesthetics designed to give you the best possible holeshot out of the gate.

COBALTMINI

● ● COLOR - black/cyan



NEW COLORWAY



17.5"
20" x 1-1/8

P. 03

* Final product may vary in appearance!

Radio Raceline
Complete Bikes 2020

● ● COLOR - black/neon yellow

COBALTMINI



17.5"
20" x 1-1/8

Radio Raceline
Complete Bikes 2020

* Final product may vary in appearance!

P. 04

COBALTMINI

● ● COLOR - black/red



17.5"
20" x 1-1/8



P. 05

* Final product may vary in appearance!

Radio Raceline
Complete Bikes 2020

COBALTMINI



FRAME	6061 T6 alloy
FORK	crmo, 1" butted steerer tube, hi-ten fork legs
BAR	6061 T6 alloy
GRIPS	RADIO, diamond knurling, closed end, 115mm length
STEM	RADIO, Cobalt toploader, ext. 40mm, alloy
HEADSET	FSA, TH-388, threadless headset, 1"
LEVER	rear, Promax, XL-378
BRAKES	rear, Promax, MV-87
CRANKS	RADIO, Cobalt 3pc crank, forged/cnc, alloy crank, 145mm length
BB	RADIO, BSA square taper, sealed
PEDALS	RADIO, Mini, PC, crmo axle
CHAIN	KMC, Z410, 1/2" x 1/8"
SPROCKET	RADIO, 36T, alloy
DRIVER	ATA, 14T, 1/2" x 1/8", crmo
FRONT HUB	RADIO, Cobalt hub, alloy cnc, fully sealed, 28T, 3/8" crmo axle
REAR HUB	RADIO, Cobalt hub, alloy cnc, fully sealed, 28T, flip flop, 3/8" crmo axle
RIMS	RADIO, R450, double wall, 28H, alloy
SEAT	RADIO, Mini, combo seat
SEAT POST	RADIO, 22.2mm alloy seatpost
SEAT CLAMP	RADIO, seat clamp, forged, alloy
TIRES	Tioga, Power-Block, 20" x 1-1/8"
WEIGHT	6.91 kg - 15.23lbs



* Final product may vary in appearance!

TOP TUBE LENGTH	17.5"	HEAD TUBE ANGLE	72°	BAR RISE	2.25"	BACKSWEEP	8°
CHAIN STAY LENGTH	13.1"	SEAT TUBE ANGLE	70°	BAR WIDTH	21"	UPSWEEP	2°
BOTTOM BRACKET HEIGHT	10.7"						

COBALTJUNIOR

● ● COLOR - black/cyan



NEW COLORWAY



18.5"
20" x 1-1/8

P. 07

* Final product may vary in appearance!

Radio Raceline
Complete Bikes 2020

● ● COLOR - black/neon yellow

COBALTJUNIOR



18.5"
20" x 1-1/8

Radio Raceline
Complete Bikes 2020

* Final product may vary in appearance!

P. 08

COBALTJUNIOR

● ● COLOR - black/red



18.5"
20" x 1-1/8



P. 09

* Final product may vary in appearance!

Radio Raceline
Complete Bikes 2020

COBALT JUNIOR



FRAME	6061 T6 alloy
FORK	crmo, 1" butted steerer tube, hi-ten fork legs
BAR	6061 T6 alloy
GRIPS	RADIO, diamond knurling, closed end, 130mm length
STEM	RADIO, Cobalt toploader, ext. 40mm, alloy
HEADSET	FSA, TH-388, threadless headset, 1"
LEVER	rear, Promax, XL-378
BRAKES	rear, Promax, MV-87
CRANKS	RADIO, Cobalt 3pc crank, forged/cnc, alloy crank, 155mm length
BB	RADIO, BSA square taper, sealed
PEDALS	RADIO, Mini, PC, crmo axle
CHAIN	KMC, Z410, 1/2" x 1/8"
SPROCKET	RADIO, 38T, alloy
DRIVER	ATA, 14T, 1/2" x 1/8", crmo
FRONT HUB	RADIO, Cobalt hub, alloy cnc, fully sealed, 28T, 3/8" crmo axle
REAR HUB	RADIO, Cobalt hub, alloy cnc, fully sealed, 28T, flip flop, 3/8" crmo axle
RIMS	RADIO, R450, double wall, 28H, alloy
SEAT	RADIO, Mini, combo seat
SEAT POST	RADIO, 22.2mm alloy seatpost
SEAT CLAMP	RADIO, seat clamp, forged, alloy
TIRES	Tioga, Power-Block, 20" x 1-1/8"
WEIGHT	7,17 kg - 15.8lbs



* Final product may vary in appearance!

TOP TUBE LENGTH	18.5"	HEAD TUBE ANGLE	73°	BAR RISE	4.25"	BACKSWEEP	8°
CHAIN STAY LENGTH	12.85"	SEAT TUBE ANGLE	71°	BAR WIDTH	22.8"	UPSWEEP	2°
BOTTOM BRACKET HEIGHT	10.6"						

COBALTEXPERT

● ● COLOR - black/cyan



NEW COLORWAY

19.5"
20" x 1-3/8



P. 11

* Final product may vary in appearance!

Radio Raceline
Complete Bikes 2020

● ● COLOR - black/neon yellow

COBALTEXPERT



19.5"
20" x 1-3/8

Radio Raceline
Complete Bikes 2020

* Final product may vary in appearance!

P. 12

COBALTEXPERT

● ● COLOR - black/red



19.5"
20" x 1-3/8



P. 13

* Final product may vary in appearance!

Radio Raceline
Complete Bikes 2020

COBALTEXPERT



FRAME	6061 T6 alloy
FORK	crmo, 1" butted steerer tube, hi-ten fork legs
BAR	6061 T6 alloy
GRIPS	RADIO, zigzag tread, open end, rubber plug incl., 145mm length
STEM	RADIO, Cobalt toploader, ext. 50mm, alloy
HEADSET	FSA, No.28, threadless headset, 1-1/8"
LEVER	rear, Promax, XL-378
BRAKES	rear, Promax, MV-85
CRANKS	RADIO, Cobalt 3pc crank, forged/cnc, alloy crank, 165mm length
BB	RADIO, BSA square taper, sealed
PEDALS	RADIO, Expert, PC, crmo axle
CHAIN	KMC, Z410, 1/2" x 1/8"
SPROCKET	RADIO, 39T, alloy
DRIVER	ATA, 15T, 1/2" x 1/8", crmo
FRONT HUB	RADIO, Cobalt hub, alloy cnc, fully sealed, 28T, 3/8" crmo axle
REAR HUB	RADIO, Cobalt hub, alloy cnc, fully sealed, 28T, flip flop, 3/8" crmo axle
RIMS	RADIO, R450, double wall, 28H, alloy
SEAT	RADIO, pivotal, no padding
SEAT POST	RADIO, 26.8mm, pivotal alloy
SEAT CLAMP	RADIO, seat clamp, forged, alloy
TIRES	Tioga, Power-Block, 20" x 1-3/8"
WEIGHT	7,72 kg - 17.01lbs



* Final product may vary in appearance!

TOP TUBE LENGTH	19.5"	HEAD TUBE ANGLE	73°	BAR RISE	5.75"	BACKSWEEP	8°
CHAIN STAY LENGTH	13.6"	SEAT TUBE ANGLE	71°	BAR WIDTH	24.4"	UPSWEEP	2°
BOTTOM BRACKET HEIGHT	11"						

COBALTPRO

● ● COLOR - black/cyan



NEW PRODUCT

20.75"
F: 20" x 1.75" - R: 20" x 1.6"



P. 15

* Final product may vary in appearance!

Radio Raceline
Complete Bikes 2020

● ● COLOR - black/neon yellow

COBALTPRO

NEW PRODUCT



20.75"
F: 20" x 1.75" - R: 20" x 1.6"

Radio Raceline
Complete Bikes 2020

* Final product may vary in appearance!

P. 16

COBALTPRO

● ● COLOR - black/red



NEW PRODUCT

20.75"
F: 20" x 1.75" - R: 20" x 1.6"



P. 17

* Final product may vary in appearance!

Radio Raceline
Complete Bikes 2020

COBALTPRO



FRAME	6061 T6 alloy
FORK	full crmo, 1-1/8" butted steertube
BARS	4130 seamless crmo
GRIPS	RADIO, zigzag tread, open end, rubber plug incl., 145mm length
STEM	RADIO, Cobalt toploader, ext. 50mm, alloy
HEADSET	FSA, Pro, int. headset, sealed, threadless, 1-1/8"
LEVER	rear, Promax, XL-378
BRAKES	rear, Promax, MV-85
CRANKS	RADIO, Cobalt 3pc crank, forged/cnc, alloy crank, 175mm length
BB	RADIO, BSA square taper, sealed
PEDALS	RADIO, Pro, PC, crmo axle
CHAIN	KMC, Z410, 1/2" x 1/8"
SPROCKET	RADIO, 44T, alloy
DRIVER	ATA, 16T, 1/2" x 1/8", crmo
FRONT HUB	RADIO, Cobalt hub, alloy cnc, fully sealed, 32T, 3/8" crmo axle
REAR HUB	RADIO, Cobalt hub, alloy cnc, fully sealed, 32T, flip flop, 3/8" crmo axle
RIMS	Alex, MUS30, 32H, alloy
SEAT	RADIO, pivotal, no padding
SEAT POST	RADIO, 26.8mm, pivotal alloy
SEAT CLAMP	RADIO, seat clamp, forged, alloy
TIRES	Tioga, Power-Block, front: 20"x1.75" / rear: 20"x1.6"
WEIGHT	tba

TOP TUBE LENGTH	20.75"	HEAD TUBE ANGLE	74°	BAR RISE	7.5"	BACKSWEEP	11°
CHAIN STAY LENGTH	14.3"	SEAT TUBE ANGLE	72°	BAR WIDTH	26.75"	UPSWEEP	3.5°
BOTTOM BRACKET HEIGHT	11.5"						

XENONMINI

● ● COLOR - black/metallic purple



NEW COLORWAY



17.5"
20" x 1-1/8

P. 19

* Final product may vary in appearance!

Radio Raceline
Complete Bikes 2020

XENONMINI

54

FRAME	6061 T6 alloy, forged dropouts with int. chain tensioner
FORK	full crmo, 1" butted steerer tube
BARS	6061 T6 alloy
GRIPS	RADIO, diamond knurling, closed end, 115mm length
STEM	RADIO, Cobalt toploader, ext. 40mm, alloy
HEADSET	Tange, int. headset, sealed, threadless, 1"
LEVER	rear, Promax, XL-378
BRAKES	rear, Promax, MV-85
CRANKS	RADIO, Cobalt 3pc crank, forged/cnc, alloy crank, 145mm length
BB	RADIO, BSA square taper, sealed
PEDALS	RADIO, Xenon pedal, slim profile, alloy, crmo axle
CHAIN	KMC, Z33, 1/2"- 3/32"
SPROCKET	RADIO, 38T, alloy
DRIVER	RADIO, 16T cog, 1/2"- 3/32", sealed driver
FRONT HUB	RADIO, Xenon hub, alloy cnc, fully sealed, 28T, 3/8" axle
REAR HUB	RADIO, Xenon hub, alloy cnc, fully sealed, 28T, cassette
RIMS	Alienation, Ankle Biter, 28H, alloy
SEAT	RADIO, Mini, combo seat
SEAT POST	RADIO, 22.2mm alloy seatpost
SEAT CLAMP	RADIO, seat clamp, forged, alloy
TIRES	Tioga, Power-Block, 20" x 1-1/8"
WEIGHT	7,10 kg - 15.65lbs

TOP TUBE LENGTH	17.5"	HEAD TUBE ANGLE	72°	BAR RISE	2.25"	BACKSWEEP	8°
CHAIN STAY LENGTH	13.1"	SEAT TUBE ANGLE	70°	BAR WIDTH	21"	UPSWEEP	2°
BOTTOM BRACKET HEIGHT	10.6"						

XENONMINI

● ● COLOR - black/silver



17.5"
20" x 1-1/8



P. 21

* Final product may vary in appearance!

Radio Raceline
Complete Bikes 2020

XENONMINI

54

FRAME	6061 T6 alloy, forged dropouts with int. chain tensioner
FORK	full crmo, 1" butted steerer tube
BAR	6061 T6 alloy
GRIPS	RADIO, diamond knurling, closed end, 115mm length
STEM	RADIO, Cobalt toploader, ext. 40mm, alloy
HEADSET	Tange, int. headset, sealed, threadless, 1"
LEVER	rear, Promax, XL-378
BRAKES	rear, Promax, MV-85
CRANKS	RADIO, Cobalt 3pc crank, forged/cnc, alloy crank, 145mm length
BB	RADIO, BSA square taper, sealed
PEDALS	RADIO, Xenon pedal, slim profile, alloy, crmo axle
CHAIN	KMC, Z33, 1/2"- 3/32"
SPROCKET	RADIO, 38T, alloy
DRIVER	RADIO, 16T cog, 1/2"- 3/32", sealed driver
FRONT HUB	RADIO, Xenon hub, alloy cnc, fully sealed, 28T, 3/8" axle
REAR HUB	RADIO, Xenon hub, alloy cnc, fully sealed, 28T, cassette
RIMS	Alienation, Ankle Biter, 28H, alloy
SEAT	RADIO, Mini, combo seat
SEAT POST	RADIO, 22.2mm alloy seatpost
SEAT CLAMP	RADIO, seat clamp, forged, alloy
TIRES	Tioga, Power-Block, 20" x 1-1/8"
WEIGHT	7,10 kg - 15.65lbs



* Final product may vary in appearance!

TOP TUBE LENGTH	17.5"	HEAD TUBE ANGLE	72°	BAR RISE	2.25"	BACKSWEEP	8°
CHAIN STAY LENGTH	13.1"	SEAT TUBE ANGLE	70°	BAR WIDTH	21"	UPSWEEP	2°
BOTTOM BRACKET HEIGHT	10.6"						

XENONJUNIOR

● ● COLOR - black/metallic purple



NEW COLORWAY

18.5"
20" x 1-1/8



P. 23

* Final product may vary in appearance!

Radio Raceline
Complete Bikes 2020

XENONJUNIOR

54

FRAME	6061 T6 alloy, forged dropouts with int. chain tensioner
FORK	full crmo, 1" butted steerer tube
BAR	6061 T6 alloy
GRIPS	RADIO, diamond knurling, closed end, 130mm length
STEM	RADIO, Cobalt toploader, ext. 40mm, alloy
HEADSET	Tange, int. headset, sealed, threadless, 1"
LEVER	rear, Promax, XL-378
BRAKES	rear, Promax, MV-85
CRANKS	RADIO, Cobalt 3pc crank, forged/cnc, alloy crank, 155mm length
BB	RADIO, BSA square taper, sealed
PEDALS	RADIO, Xenon pedal, slim profile, alloy, crmo axle
CHAIN	KMC, Z33, 1/2"- 3/32"
SPROCKET	RADIO, 38T, alloy
DRIVER	RADIO, 14T cog, 1/2"- 3/32", sealed driver
FRONT HUB	RADIO, Xenon hub, alloy cnc, fully sealed, 28T, 3/8" axle
REAR HUB	RADIO, Xenon hub, alloy cnc, fully sealed, 28T, cassette
RIMS	Alienation, Ankle Biter, 28H, alloy
SEAT	RADIO, Mini, combo seat
SEAT POST	RADIO, 22.2mm alloy seatpost
SEAT CLAMP	RADIO, seat clamp, forged, alloy
TIRES	Tioga, Power-Block, 20" x 1-1/8"
WEIGHT	7,25 kg - 15.98lbs

TOP TUBE LENGTH	18.5"	HEAD TUBE ANGLE	73°	BAR RISE	4.25"	BACKSWEEP	8°
CHAIN STAY LENGTH	12.85"	SEAT TUBE ANGLE	71°	BAR WIDTH	22.8"	UPSWEEP	2°
BOTTOM BRACKET HEIGHT	10.6"						

XENONJUNIOR

● ● COLOR - black/silver



18.5"
20" x 1-1/8



P. 25

* Final product may vary in appearance!

Radio Raceline
Complete Bikes 2020

XENONJUNIOR

54

FRAME	6061 T6 alloy, forged dropouts with int. chain tensioner
FORK	full crmo, 1" butted steerer tube
BAR	6061 T6 alloy
GRIPS	RADIO, diamond knurling, closed end, 130mm length
STEM	RADIO, Cobalt toploader, ext. 40mm, alloy
HEADSET	Tange, int. headset, sealed, threadless, 1"
LEVER	rear, Promax, XL-378
BRAKES	rear, Promax, MV-85
CRANKS	RADIO, Cobalt 3pc crank, forged/cnc, alloy crank, 155mm length
BB	RADIO, BSA square taper, sealed
PEDALS	RADIO, Xenon pedal, slim profile, alloy, crmo axle
CHAIN	KMC, Z33, 1/2"- 3/32"
SPROCKET	RADIO, 38T, alloy
DRIVER	RADIO, 14T cog, 1/2"- 3/32", sealed driver
FRONT HUB	RADIO, Xenon hub, alloy cnc, fully sealed, 28T, 3/8" axle
REAR HUB	RADIO, Xenon hub, alloy cnc, fully sealed, 28T, cassette
RIMS	Alienation, Ankle Biter, 28H, alloy
SEAT	RADIO, Mini, combo seat
SEAT POST	RADIO, 22.2mm alloy seatpost
SEAT CLAMP	RADIO, seat clamp, forged, alloy
TIRES	Tioga, Power-Block, 20" x 1-1/8"
WEIGHT	7,25 kg - 15.98lbs



* Final product may vary in appearance!

TOP TUBE LENGTH	18.5"	HEAD TUBE ANGLE	73°	BAR RISE	4.25"	BACKSWEEP	8°
CHAIN STAY LENGTH	12.85"	SEAT TUBE ANGLE	71°	BAR WIDTH	22.8"	UPSWEEP	2°
BOTTOM BRACKET HEIGHT	10.6"						

XENONEXPERT

● ● COLOR - black/metallic purple



NEW COLORWAY

19.5"
20" x 1-3/8



P. 27

* Final product may vary in appearance!

Radio Raceline
Complete Bikes 2020

XENON **EXPERT**

54

FRAME	6061 T6 alloy, forged dropouts with int. chain tensioner
FORK	full crmo, 1-1/8" butted steerer tube
BAR	6061 T6 alloy
GRIPS	RADIO, zigzag tread, open end, rubber plug incl., 145mm length
STEM	RADIO, Cobalt toploader, ext. 50mm, alloy
HEADSET	FSA, Pro, int. headset, sealed, threadless, 1-1/8"
LEVER	rear, Promax, XL-378
BRAKES	rear, Promax, MV-85
CRANKS	RADIO, Cobalt 3pc crank, forged/cnc, alloy crank, 165mm length
BB	RADIO, BSA square taper, sealed
PEDALS	RADIO, Xenon pedal, slim profile, alloy, crmo axle
CHAIN	KMC, Z33, 1/2"- 3/32"
SPROCKET	RADIO, 39T, alloy
DRIVER	RADIO, 15T cog, 1/2"- 3/32", sealed driver
FRONT HUB	RADIO, Xenon hub, alloy cnc, fully sealed, 28T, 3/8" axle
REAR HUB	RADIO, Xenon hub, alloy cnc, fully sealed, 28T, cassette
RIMS	Alienation, Ankle Biter, 28H, alloy
SEAT	RADIO, pivotal, no padding
SEAT POST	RADIO, 26.8mm, pivotal alloy
SEAT CLAMP	RADIO, Xenon seat clamp, quick-release, alloy
TIRES	Tioga, Power-Block, 20" x 1-3/8"
WEIGHT	7.88 kg - 17.37lbs

TOP TUBE LENGTH	19.5"	HEAD TUBE ANGLE	73°	BAR RISE	5.75"	BACKSWEEP	8°
CHAIN STAY LENGTH	13.6"	SEAT TUBE ANGLE	71°	BAR WIDTH	24.4"	UPSWEEP	2°
BOTTOM BRACKET HEIGHT	11"						

XENONEXPERT

● ● COLOR - black/silver



19.5"
20" x 1-3/8



P. 29

* Final product may vary in appearance!

Radio Raceline
Complete Bikes 2020

XENONEXPERT

54

FRAME	6061 T6 alloy, forged dropouts with int. chain tensioner
FORK	full crmo, 1-1/8" butted steerer tube
BAR	6061 T6 alloy
GRIPS	RADIO, zigzag tread, open end, rubber plug incl., 145mm length
STEM	RADIO, Cobalt toploader, ext. 50mm, alloy
HEADSET	FSA, Pro, int. headset, sealed, threadless, 1-1/8"
LEVER	rear, Promax, XL-378
BRAKES	rear, Promax, MV-85
CRANKS	RADIO, Cobalt 3pc crank, forged/cnc, alloy crank, 165mm length
BB	RADIO, BSA square taper, sealed
PEDALS	RADIO, Xenon pedal, slim profile, alloy, crmo axle
CHAIN	KMC, Z33, 1/2"- 3/32"
SPROCKET	RADIO, 39T, alloy
DRIVER	RADIO, 15T cog, 1/2"- 3/32", sealed driver
FRONT HUB	RADIO, Xenon hub, alloy cnc, fully sealed, 28T, 3/8" axle
REAR HUB	RADIO, Xenon hub, alloy cnc, fully sealed, 28T, cassette
RIMS	Alienation, Ankle Biter, 28H, alloy
SEAT	RADIO, pivotal, no padding
SEAT POST	RADIO, 26.8mm, pivotal alloy
SEAT CLAMP	RADIO, Xenon seat clamp, quick-release, alloy
TIRES	Tioga, Power-Block, 20" x 1-3/8"
WEIGHT	7.88 kg - 17.37lbs



* Final product may vary in appearance!

TOP TUBE LENGTH	19.5"	HEAD TUBE ANGLE	73°	BAR RISE	5.75"	BACKSWEEP	8°
CHAIN STAY LENGTH	13.6"	SEAT TUBE ANGLE	71°	BAR WIDTH	24.4"	UPSWEEP	2°
BOTTOM BRACKET HEIGHT	11"						

XENONEXPERT^{XL}

● ● COLOR - black/metallic purple



NEW COLORWAY

20.25"
F: 20" x 1.6" - R: 20" x 1.4"



P. 31

* Final product may vary in appearance!

Radio Raceline
Complete Bikes 2020

XENON **EXPERT** XL

54

FRAME	6061 T6 alloy, forged dropouts with int. chain tensioner
FORK	full crmo, 1-1/8" butted steerer tube
BARS	6061 T6 alloy
GRIPS	RADIO, zigzag tread, open end, rubber plug incl., 145mm length
STEM	RADIO, Cobalt toploader, ext. 50mm, alloy
HEADSET	FSA, Pro, int. headset, sealed, threadless, 1-1/8"
LEVER	rear, Promax, XL-378
BRAKES	rear, Promax, MV-85
CRANKS	RADIO, Cobalt 3pc crank, forged/cnc, alloy crank, 165mm length
BB	RADIO, BSA square taper, sealed
PEDALS	RADIO, Xenon pedal, slim profile, alloy, crmo axle
CHAIN	KMC, Z33, 1/2"- 3/32"
SPROCKET	RADIO, 39T, alloy
DRIVER	RADIO, 15T cog, 1/2"- 3/32", sealed driver
FRONT HUB	RADIO, Xenon hub, alloy cnc, fully sealed, 28T, 3/8" axle
REAR HUB	RADIO, Xenon hub, alloy cnc, fully sealed, 28T, cassette
RIMS	Alex, MUS30, 32H, alloy
SEAT	RADIO, pivotal, no padding
SEAT POST	RADIO, 26.8mm, pivotal alloy
SEAT CLAMP	RADIO, Xenon seat clamp, quick-release, alloy
TIRES	Tioga, Power-Block, front: 20"x1.6" / rear: 20"x1.4"
WEIGHT	8,15 kg - 17.96lbs

TOP TUBE LENGTH	20.25"	HEAD TUBE ANGLE	73°	BAR RISE	7"	BACKSWEEP	8°
CHAIN STAY LENGTH	13.6"	SEAT TUBE ANGLE	71°	BAR WIDTH	26.25"	UPSWEEP	2°
BOTTOM BRACKET HEIGHT	11"						

XENONEXPERT^{XL}

● ● COLOR - black/silver



19.5"
20" x 1-3/8



P. 33

* Final product may vary in appearance!

Radio Raceline
Complete Bikes 2020

XENON EXPERT XL

54

FRAME	6061 T6 alloy, forged dropouts with int. chain tensioner
FORK	full crmo, 1-1/8" butted steerer tube
BAR	6061 T6 alloy
GRIPS	RADIO, zigzag tread, open end, rubber plug incl., 145mm length
STEM	RADIO, Cobalt toploader, ext. 50mm, alloy
HEADSET	FSA, Pro, int. headset, sealed, threadless, 1-1/8"
LEVER	rear, Promax, XL-378
BRAKES	rear, Promax, MV-85
CRANKS	RADIO, Cobalt 3pc crank, forged/cnc, alloy crank, 165mm length
BB	RADIO, BSA square taper, sealed
PEDALS	RADIO, Xenon pedal, slim profile, alloy, crmo axle
CHAIN	KMC, Z33, 1/2"- 3/32"
SPROCKET	RADIO, 39T, alloy
DRIVER	RADIO, 15T cog, 1/2"- 3/32", sealed driver
FRONT HUB	RADIO, Xenon hub, alloy cnc, fully sealed, 28T, 3/8" axle
REAR HUB	RADIO, Xenon hub, alloy cnc, fully sealed, 28T, cassette
RIMS	Alex, MUS30, 32H, alloy
SEAT	RADIO, pivotal, no padding
SEAT POST	RADIO, 26.8mm, pivotal alloy
SEAT CLAMP	RADIO, Xenon seat clamp, quick-release, alloy
TIRES	Tioga, Power-Block, front: 20"x1.6" / rear: 20"x1.4"
WEIGHT	8,15 kg - 17.96lbs



* Final product may vary in appearance!

TOP TUBE LENGTH	20.25"	HEAD TUBE ANGLE	73°	BAR RISE	7"	BACKSWEEP	8°
CHAIN STAY LENGTH	13.6"	SEAT TUBE ANGLE	71°	BAR WIDTH	26.25"	UPSWEEP	2°
BOTTOM BRACKET HEIGHT	11"						

XENONPRO

● ● COLOR - black/metallic purple



NEW COLORWAY

20.75"
F: 20" x 1.75" - R: 20" x 1.6"



P. 35

* Final product may vary in appearance!

Radio Raceline
Complete Bikes 2020

XENONPRO

54

FRAME	6061 T6 alloy, forged dropouts with int. chain tensioner
FORK	full crmo, 1-1/8" butted steerer tube
BAR	4130 seamless crmo
GRIPS	RADIO, Xenon grip, diamond knurling, clamp on grip, 139mm length
STEM	RADIO, Xenon Pro stem, toploader, ext. 53mm, cold forged/cnc alloy
HEADSET	FSA, Pro, int. headset, sealed, threadless, 1-1/8"
LEVER	rear, Promax, XL-378
BRAKES	rear, Promax, MV-88
CRANKS	RADIO, Xenon Pro, 2pc crank, cold forged/cnc, alloy, 175mm length, 24mm spindle
BB	RADIO, BSA24, alloy, cnc external bearing cups, sealed
PEDALS	RADIO, Xenon pedal, slim profile, alloy, crmo axle
CHAIN	KMC, Z33, 1/2"- 3/32"
SPROCKET	RADIO, Xenon Pro sprocket, 44T, alloy
DRIVER	RADIO, 16T cog, 1/2"- 3/32", sealed driver
FRONT HUB	RADIO, Xenon Pro hub, alloy cnc, fully sealed, female bolt axle, highend front hub, 32T
REAR HUB	RADIO, Xenon Pro hub, alloy cnc, fully sealed, female bolt, highend cassette hub, 36T
RIMS	front: Alex, DUS30, 32H, double wall, alloy / rear: Alex, DUS30, 36H, double wall, alloy
SEAT	RADIO, pivotal, no padding
SEAT POST	RADIO, 26.8mm, pivotal alloy
SEAT CLAMP	RADIO, Xenon seat clamp, quick-release, alloy
TIRES	Tioga, Power-Block, front: 20"x1.75" / rear: 20"x1.6"
WEIGHT	9.05 kg - 19.95lbs

TOP TUBE LENGTH	20.75"	HEAD TUBE ANGLE	74°	BAR RISE	7.5"	BACKSWEEP	11°
CHAIN STAY LENGTH	14.3"	SEAT TUBE ANGLE	72°	BAR WIDTH	26.75"	UPSWEEP	3.5°
BOTTOM BRACKET HEIGHT	11.5"						

XENONPRO

● ○ COLOR - black/white



20.75"
F: 20" x 1.75" - R: 20" x 1.6"



P. 37

* Final product may vary in appearance!

Radio Raceline
Complete Bikes 2020

XENONPRO

54

FRAME	6061 T6 alloy, forged dropouts with int. chain tensioner
FORK	full crmo, 1-1/8" butted steerer tube
BAR	4130 seamless crmo
GRIPS	RADIO, Xenon grip, diamond knurling, clamp on grip, 139mm length
STEM	RADIO, Xenon Pro stem, toploader, ext. 53mm, cold forged/cnc alloy
HEADSET	FSA, Pro, int. headset, sealed, threadless, 1-1/8"
LEVER	rear, Promax, XL-378
BRAKES	rear, Promax, MV-88
CRANKS	RADIO, Xenon Pro, 2pc crank, cold forged/cnc, alloy, 175mm length, 24mm spindle
BB	RADIO, BSA24, alloy, cnc external bearing cups, sealed
PEDALS	RADIO, Xenon pedal, slim profile, alloy, crmo axle
CHAIN	KMC, Z33, 1/2" - 3/32"
SPROCKET	RADIO, Xenon Pro sprocket, 44T, alloy
DRIVER	RADIO, 16T cog, 1/2" - 3/32", sealed driver
FRONT HUB	RADIO, Xenon Pro hub, alloy cnc, fully sealed, female bolt axle, highend front hub, 32T
REAR HUB	RADIO, Xenon Pro hub, alloy cnc, fully sealed, female bolt, highend cassette hub, 36T
RIMS	front: Alex, DUS30, 32H, double wall, alloy / rear: Alex, DUS30, 36H, double wall, alloy
SEAT	RADIO, pivotal, no padding
SEAT POST	RADIO, 26.8mm, pivotal alloy
SEAT CLAMP	RADIO, Xenon seat clamp, quick-release, alloy
TIRES	Tioga, Power-Block, front: 20"x1.75" / rear: 20"x1.6"
WEIGHT	9.05 kg - 19.95lbs



* Final product may vary in appearance!

TOP TUBE LENGTH	20.75"	HEAD TUBE ANGLE	74°	BAR RISE	7.5"	BACKSWEEP	11°
CHAIN STAY LENGTH	14.3"	SEAT TUBE ANGLE	72°	BAR WIDTH	26.75"	UPSWEEP	3.5°
BOTTOM BRACKET HEIGHT	11.5"						

XENONPRO^{XL}

● ● COLOR - black/metallic purple



NEW COLORWAY

21.25"
F: 20" x 1.75" - R: 20" x 1.6"



P. 39

* Final product may vary in appearance!

Radio Raceline
Complete Bikes 2020

XENONPRO^{XL}

54

FRAME	6061 T6 alloy, forged dropouts with int. chain tensioner
FORK	full crmo, 1-1/8" butted steerer tube
BAR	4130 seamless crmo
GRIPS	RADIO, Xenon grip, diamond knurling, clamp on grip, 139mm length
STEM	RADIO, Xenon Pro stem, toploader, ext. 53mm, cold forged/cnc alloy
HEADSET	FSA, Pro, int. headset, sealed, threadless, 1-1/8"
LEVER	rear, Promax, XL-378
BRAKES	rear, Promax, MV-88
CRANKS	RADIO, Xenon Pro, 2pc crank, cold forged/cnc, alloy, 175mm length, 24mm spindle
BB	RADIO, BSA24, alloy, cnc external bearing cups, sealed
PEDALS	RADIO, Xenon pedal, slim profile, alloy, crmo axle
CHAIN	KMC, Z33, 1/2"- 3/32"
SPROCKET	RADIO, Xenon Pro sprocket, 44T, alloy
DRIVER	RADIO, 16T cog, 1/2"- 3/32", sealed driver
FRONT HUB	RADIO, Xenon Pro hub, alloy cnc, fully sealed, female bolt axle, highend front hub, 32T
REAR HUB	RADIO, Xenon Pro hub, alloy cnc, fully sealed, female bolt, highend cassette hub, 36T
RIMS	front: Alex, DUS30, 32H, double wall, alloy / rear: Alex, DUS30, 36H, double wall, alloy
SEAT	RADIO, pivotal, no padding
SEAT POST	RADIO, 26.8mm, pivotal alloy
SEAT CLAMP	RADIO, Xenon seat clamp, quick-release, alloy
TIRES	Tioga, Power-Block, front: 20"x1.75" / rear: 20"x1.6"
WEIGHT	9,10 kg - 20.06lbs

TOP TUBE LENGTH	21.25"	HEAD TUBE ANGLE	74°	BAR RISE	8"	BACKSWEEP	12°
CHAIN STAY LENGTH	14.3"	SEAT TUBE ANGLE	72°	BAR WIDTH	28"	UPSWEEP	1°
BOTTOM BRACKET HEIGHT	11.5"						

XENONPRO^{XL}

● ○ COLOR - black/white



21.25"
F: 20" x 1.75" - R: 20" x 1.6"



P. 41

* Final product may vary in appearance!

Radio Raceline
Complete Bikes 2020

XENONPRO^{XL}

54

FRAME	6061 T6 alloy, forged dropouts with int. chain tensioner
FORK	full crmo, 1-1/8" butted steerer tube
BAR	4130 seamless crmo
GRIPS	RADIO, Xenon grip, diamond knurling, clamp on grip, 139mm length
STEM	RADIO, Xenon Pro stem, toploader, ext. 53mm, cold forged/cnc alloy
HEADSET	FSA, Pro, int. headset, sealed, threadless, 1-1/8"
LEVER	rear, Promax, XL-378
BRAKES	rear, Promax, MV-88
CRANKS	RADIO, Xenon Pro, 2pc crank, cold forged/cnc, alloy, 175mm length, 24mm spindle
BB	RADIO, BSA24, alloy, cnc external bearing cups, sealed
PEDALS	RADIO, Xenon pedal, slim profile, alloy, crmo axle
CHAIN	KMC, Z33, 1/2" - 3/32"
SPROCKET	RADIO, Xenon Pro sprocket, 44T, alloy
DRIVER	RADIO, 16T cog, 1/2" - 3/32", sealed driver
FRONT HUB	RADIO, Xenon Pro hub, alloy cnc, fully sealed, female bolt axle, highend front hub, 32T
REAR HUB	RADIO, Xenon Pro hub, alloy cnc, fully sealed, female bolt, highend cassette hub, 36T
RIMS	front: Alex, DUS30, 32H, double wall, alloy / rear: Alex, DUS30, 36H, double wall, alloy
SEAT	RADIO, pivotal, no padding
SEAT POST	RADIO, 27.2mm, pivotal alloy
SEAT CLAMP	RADIO, Xenon seat clamp, quick-release, alloy
TIRES	Tioga, Power-Block, front: 20"x1.75" / rear: 20"x1.6"
WEIGHT	9,10 kg - 20.06lbs



* Final product may vary in appearance!

TOP TUBE LENGTH	21.25"	HEAD TUBE ANGLE	74°	BAR RISE	8"	BACKSWEEP	12°
CHAIN STAY LENGTH	14.3"	SEAT TUBE ANGLE	72°	BAR WIDTH	28"	UPSWEEP	1°
BOTTOM BRACKET HEIGHT	11.5"						

HELIUMCRUISER

● ● COLOR - black/gold



NEW PRODUCT

22"
F: 24" x 1.75" - R: 24" x 1.6"



P. 43

* Final product may vary in appearance!

Radio Raceline
Complete Bikes 2020

HELIUMCRUISER



FRAME	hydro formed 6061 T6 alloy, forged dropouts, 1 1/8" -1.5" taper headtube
FORK	full crmo, 1-1/8" butted steerer tube
BAR	4130 seamless crmo
GRIPS	RADIO, Xenon grip, diamond knurling, clamp on grip, 139mm length
STEM	RADIO, Xenon Pro stem, toploader, ext. 53mm, cold forged/cnc alloy
HEADSET	Radio, Pro, int. headset, sealed, threadless, 1-1/8" - 1.5", including fork crown race 1.5"-1 1/8" converter
LEVER	rear, Promax, XL-373
BRAKES	rear, Promax, MV-88
CRANKS	RADIO, Xenon Pro, 2pc crank, cold forged/cnc, alloy, 180mm length, 24mm spindle
BB	RADIO, BSA24, alloy, cnc external bearing cups, sealed
PEDALS	RADIO, Xenon pedal, slim profile, alloy, crmo axle
CHAIN	KMC, Z33, 1/2"- 3/32"
SPROCKET	RADIO, Xenon Pro sprocket, 41T, alloy
DRIVER	RADIO, 18T cog, 1/2"- 3/32", sealed driver
FRONT HUB	RADIO, Xenon Pro hub, alloy cnc, fully sealed, female bolt axle, highend front hub, 32T
REAR HUB	RADIO, Xenon Pro hub, alloy cnc, fully sealed, female bolt, highend cassette hub, 36T
RIMS	front: Alex, MUS30, 32H, alloy / rear: Alex, MUS30, 36H, alloy
SEAT	RADIO, pivotal, no padding
SEAT POST	RADIO, 26.8mm, pivotal alloy
SEAT CLAMP	RADIO, Xenon seat clamp, quick-release, alloy
TIRES	Tioga, Power-Block, front: 24"x1.75" / rear: 24"x1.6"
WEIGHT	tba

TOP TUBE LENGTH	22"	HEAD TUBE ANGLE	74°	BAR RISE	6"	BACKSWEEP	8°
CHAIN STAY LENGTH	15.15"	SEAT TUBE ANGLE	71°	BAR WIDTH	26.75"	UPSWEEP	2°
BOTTOM BRACKET HEIGHT	12"						



RADIO RACELINE
Richard-Byrd-Str. 12
50829 Cologne / Germany
mail@radiobikes.com

© WE MAKE THINGS GmbH, all rights reserved.

RADIO

PARTS AND ACCESSORIES

21 |

20



RADIO RACELINE

combines over 20 years of experience of creating BMX bikes together with input from some of the world's best racers and industry players to create a revolutionary and all-encompassing line up of bikes built to take you to the finish line, unlike anything else.

Tested on the track and designed in conjunction with a team with BMX race knowledge spanning 3 decades, RADIO RACELINE enters the market with an incredibly well thought out and powerful line of pure bred race machines.

Building off a hugely successful first year, the 2020 line of HELIUM frames gains a healthy injection of exciting new colourways and a new XXXXL size option for riders wanting a lengthier steed. We're also proud to release our new disc brake mount allowing you to upgrade your HELIUM PRO frame into a full disc-ready setup in a matter of seconds.

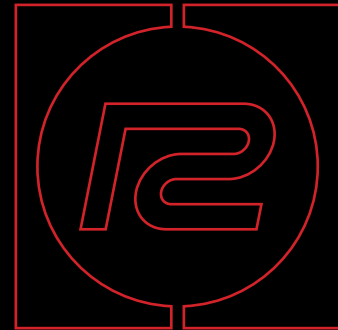

RADIOBIKES.COM

21 |

20 PARTS AND
ACCESSORIES



photos by Steve Diamond Elements

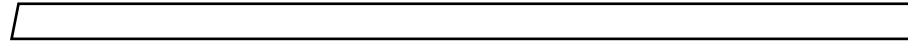

From our entry level bikes all the way through to our aftermarket frames, all RADIO RACELINE products are designed to feel comfortable, solid and fast, exactly how a race bike should.

You'll find no gimmicks on any of our bikes, no "goofy" tubing shapes or unnecessary features. Our bikes have been built from the ground up with race proven geometry and technology combined with clean, functional aesthetics designed to give you the best possible holeshot out of the gate.



RADIO
RACELINE

P. 03

HELIUM MINI

HELIUM JUNIOR

NEW COLORWAY

● COLOR - black



21 |

20 PARTS AND
ACCESSORIES

* Final product will vary in appearance! Images show the Helium Junior model only.

RADIO
RACERLINE

P. 04

HELIUM MINI

HELIUM JUNIOR



NEW COLORWAY

● COLOR - metallic red



21

20 PARTS AND ACCESSORIES

* Final product will vary in appearance! Images show the Helium Junior model only.

RADIO
RACELINE

P. 05

HELIUM MINI FRAME

MATERIAL	Hydroformed 6061 alloy
TOP TUBE LENGTH (effective)	17.6" (447mm)
CHAIN STAY LENGTH (min.)	12.4" (315mm)
DROPOUT SIZE	10mm
HEAD TUBE ANGLE	73°
SEAT TUBE ANGLE	70°
HEAD TUBE SIZE (full int.)	1" (110mm)
SEAT POST SIZE	22.2mm
SEAT TUBE LENGTH	200mm
BOTTOM BRACKET HEIGHT	EU, 10.6"
WHEEL SIZE	20 x 1-1/8"
RIDER AREA	456.2mm
EXTRAS	incl. PROMAX 335QX seat clamp
WEIGHT	1.250kg (2.76lbs) inc. seat clamp

● **COLOR** - black

● **COLOR** - metallic red

HELIUM JUNIOR FRAME

MATERIAL	Hydroformed 6061 T6 alloy
TOP TUBE LENGTH (effective)	18.6" (473mm)
CHAIN STAY LENGTH (min.)	12.8" (325mm)
DROPOUT SIZE	10mm
HEAD TUBE ANGLE	73.5°
SEAT TUBE ANGLE	71°
HEAD TUBE SIZE (full int.)	1" (110mm)
SEAT POST SIZE	22.2mm
SEAT TUBE LENGTH	210mm
BOTTOM BRACKET HEIGHT	EU, 10.6"
WHEEL SIZE	20 x 1-1/8"
RIDER AREA	483.5mm
EXTRAS	incl. PROMAX 335QX seat clamp
WEIGHT	1.320kg (2.90lbs) inc. seat clamp

● **COLOR** - black

● **COLOR** - metallic red



HELIUM EXPERT

HELIUM EXPERT XL



NEW COLORWAY

● COLOR - black



21
20

PARTS AND
ACCESSORIES

* Final product will vary in appearance! Images show the Helium Expert model only.

RADIO
RACELINE

P. 07

HELIUM EXPERT

HELIUM EXPERT XL



NEW COLORWAY

● **COLOR** - metallic cyan



21 |

20 PARTS AND
ACCESSORIES

* Final product will vary in appearance! Images show the Helium Expert model only.

RADIO
RACELINE

P. 08

HELIUM EXPERT

HELIUM EXPERT XL



NEW COLORWAY

COLOR - white



21
20

PARTS AND
ACCESSORIES

* Final product will vary in appearance! Images show the Helium Expert model only.

RADIO
RACELINE

P. 09

HELIUM EXPERT FRAME

MATERIAL	Hydroformed 6061 alloy
TOP TUBE LENGTH (effective)	19.5" (495mm)
CHAIN STAY LENGTH (min.)	13" (330mm)
DROPOUT SIZE	10mm
HEAD TUBE ANGLE	73.5°
SEAT TUBE ANGLE	71°
HEAD TUBE SIZE (full int.)	1-1/8" (120mm)
SEAT POST SIZE	22.2mm
SEAT TUBE LENGTH	215mm
BOTTOM BRACKET HEIGHT	EU, 10.8"
WHEEL SIZE	20 x 1-3/8"
RIDER AREA	503mm
EXTRAS	incl. PROMAX 335QX seat clamp
WEIGHT	1.445kg (3.24lbs) inc. seat clamp

- **COLOR** - black
- **COLOR** - metallic cyan
- **COLOR** - white

HELIUM EXPERT XL FRAME

MATERIAL	Hydroformed 6061 alloy
TOP TUBE LENGTH (effective)	20.5" (521mm)
CHAIN STAY LENGTH (min.)	13.2" (335mm)
DROPOUT SIZE	10mm
HEAD TUBE ANGLE	73.5°
SEAT TUBE ANGLE	71°
HEAD TUBE SIZE (full int.)	1-1/8" (120mm)
SEAT POST SIZE	22.2mm
SEAT TUBE LENGTH	215mm
BOTTOM BRACKET HEIGHT	EU, 10.8"
WHEEL SIZE	20 x 1.4"
RIDER AREA	526.6mm
EXTRAS	incl. PROMAX 335QX seat clamp
WEIGHT	1.585kg (3.50lbs) inc. seat clamp

- **COLOR** - black
- **COLOR** - metallic cyan
- **COLOR** - white



HELIUM PRO L - PRO XXXXL



NEW COLORWAY

● COLOR - black



21 |

20 PARTS AND ACCESSORIES

* Final product will vary in appearance! Images show the Helium Pro XL model only.

RADIO
RACELINE

P. 11

HELIUM PRO L - PRO XXXXL



NEW COLORWAY

● COLOR - silver



21
20

PARTS AND
ACCESSORIES

* Final product will vary in appearance! Images show the Helium Pro XL model only.

RADIO
RACELINE

P. 12

HELIUM PRO L - PRO XXXXL



NEW COLORWAY

● COLOR - galactic purple



21

20 PARTS AND ACCESSORIES

* Final product will vary in appearance! Images show the Helium Pro XL model only.

RADIO RACELINE

P. 13

HELIUM PRO L FRAME

MATERIAL	Hydroformed 6061 alloy
TOP TUBE LENGTH (effective)	20.9" (531mm)
CHAIN STAY LENGTH (min.)	13.9" (353mm)
DROPOUT SIZE	20mm (incl. chain tensioner for 10, 15 & 20mm hub axle)
HEAD TUBE ANGLE	74°
SEAT TUBE ANGLE	71°
HEAD TUBE SIZE (full int.)	tapered 1-1/8" - 1.5" (125mm)
SEAT POST SIZE	27.2mm
SEAT TUBE LENGTH	231mm
BOTTOM BRACKET HEIGHT	EU, 11.6"
WHEEL SIZE	20 x 1.75"
RIDER AREA	532.6mm
EXTRAS	incl. PROMAX 402QX seat clamp
WEIGHT	1.815kg (3.99lbs) inc. seat clamp

- **COLOR** - black
- **COLOR** - silver
- **COLOR** - galactic purple

HELIUM PRO XL FRAME

MATERIAL	Hydroformed 6061 alloy
TOP TUBE LENGTH (effective)	21.25" (540mm)
CHAIN STAY LENGTH (min.)	14.5" (368mm)
DROPOUT SIZE	20mm (incl. chain tensioner for 10, 15 & 20mm hub axle)
HEAD TUBE ANGLE	74°
SEAT TUBE ANGLE	71°
HEAD TUBE SIZE (full int.)	tapered 1-1/8" - 1.5" (125mm)
SEAT POST SIZE	27.2mm
SEAT TUBE LENGTH	231mm
BOTTOM BRACKET HEIGHT	EU, 11.6"
WHEEL SIZE	20 x 1.75"
RIDER AREA	540.7mm
EXTRAS	incl. PROMAX 402QX seat clamp
WEIGHT	1.840kg (4.05lbs) inc. seat clamp

- **COLOR** - black
- **COLOR** - silver
- **COLOR** - galactic purple



HELIUM PRO XXL FRAME

MATERIAL	Hydroformed 6061 alloy
TOP TUBE LENGTH (effective)	21.75" (552mm)
CHAIN STAY LENGTH (min.)	14.8" (376mm)
DROPOUT SIZE	20mm (incl. chain tensioner for 10, 15 & 20mm hub axle)
HEAD TUBE ANGLE	74°
SEAT TUBE ANGLE	71°
HEAD TUBE SIZE (full int.)	tapered 1-1/8" - 1.5" (125mm)
SEAT POST SIZE	27.2mm
SEAT TUBE LENGTH	231mm
BOTTOM BRACKET HEIGHT	EU, 11.6"
WHEEL SIZE	20 x 1.75"
RIDER AREA	551.9mm
EXTRAS	incl. PROMAX 402QX seat clamp
WEIGHT	1.870kg (4.12lbs) inc. seat clamp

- **COLOR** - black
- **COLOR** - silver
- **COLOR** - galactic purple

HELIUM PRO XXXL FRAME

MATERIAL	Hydroformed 6061 alloy
TOP TUBE LENGTH (effective)	22.25" (565mm)
CHAIN STAY LENGTH (min.)	14.8" (376mm)
DROPOUT SIZE	20mm (incl. chain tensioner for 10, 15 & 20mm hub axle)
HEAD TUBE ANGLE	74°
SEAT TUBE ANGLE	71°
HEAD TUBE SIZE (full int.)	tapered 1-1/8" - 1.5" (125mm)
SEAT POST SIZE	27.2mm
SEAT TUBE LENGTH	231mm
BOTTOM BRACKET HEIGHT	EU, 11.6"
WHEEL SIZE	20 x 1.75"
RIDER AREA	564.2mm
EXTRAS	incl. PROMAX 402QX seat clamp
WEIGHT	1.905kg (4.20lbs) inc. seat clamp

- **COLOR** - black
- **COLOR** - silver
- **COLOR** - galactic purple



HELIUM *PRO XXXXL FRAME*



MATERIAL	Hydroformed 6061 alloy
TOP TUBE LENGTH (effective)	22.5" (572mm)
CHAIN STAY LENGTH (min.)	15.2" (386mm)
DROPOUT SIZE	20mm (incl. chain tensioner for 10, 15 & 20mm hub axle)
HEAD TUBE ANGLE	74°
SEAT TUBE ANGLE	71°
HEAD TUBE SIZE (full int.)	tapered 1-1/8" - 1.5" (125mm)
SEAT POST SIZE	27.2mm
SEAT TUBE LENGTH	231mm
BOTTOM BRACKET HEIGHT	EU, 11.6"
WHEEL SIZE	20 x 1.75"
RIDER AREA	570.9mm
EXTRAS	incl. PROMAX 402QX seat clamp
WEIGHT	1.905kg (4.20lbs) inc. seat clamp

- **COLOR** - black
- **COLOR** - silver
- **COLOR** - galactic purple

HELIUM CRUISER L



● COLOR - black



21 |

20 PARTS AND
ACCESSORIES

RADIO
RACELINE

P. 17

HELIUM CRUISER XL



● COLOR - black



21 |

20 PARTS AND ACCESSORIES

RADIO
RACELINE

P. 18

HELIUM CRUISER L FRAME

MATERIAL	Hydroformed 6061 alloy
TOP TUBE LENGTH (effective)	21.5" (546mm)
CHAIN STAY LENGTH (min.)	14.6" (370mm)
DROPOUT SIZE	10mm
HEAD TUBE ANGLE	74°
SEAT TUBE ANGLE	71°
HEAD TUBE SIZE (full int.)	tapered 1-1/8" - 1.5" (125mm)
SEAT POST SIZE	27.2mm
SEAT TUBE LENGTH	260mm
BOTTOM BRACKET HEIGHT	EU, 12"
WHEEL SIZE	24 x 1.75"
RIDER AREA	564.7mm
EXTRAS	incl. PROMAX 402QX seat clamp
WEIGHT	1.865kg (4.11lbs) inc. seat clamp

● **COLOR** - black

HELIUM CRUISER XL FRAME

MATERIAL	Hydroformed 6061 alloy
TOP TUBE LENGTH (effective)	22" (559mm)
CHAIN STAY LENGTH (min.)	14.6" (370mm)
DROPOUT SIZE	10mm
HEAD TUBE ANGLE	74°
SEAT TUBE ANGLE	71°
HEAD TUBE SIZE (full int.)	tapered 1-1/8" - 1.5" (125mm)
SEAT POST SIZE	27.2mm
SEAT TUBE LENGTH	260mm
BOTTOM BRACKET HEIGHT	EU, 12"
WHEEL SIZE	24 x 1.75"
RIDER AREA	575.1mm
EXTRAS	incl. PROMAX 402QX seat clamp
WEIGHT	1.905kg (4.20lbs) inc. seat clamp

● **COLOR** - black



QUARTZ PRO - PRO XXXXL



NEW PRODUCT

● COLOR - matt black



21
20

PARTS AND
ACCESSORIES

* Final product will vary in appearance! Image shows the Quartz Pro XXL model only.

RADIO
RACERLINE

P. 20

QUARTZ PRO FRAME

MATERIAL	Hydroformed 6061 alloy, Paradigm tubing
TOP TUBE LENGTH (actual)	20.5" (520.7mm)
CHAIN STAY LENGTH (min.)	13.9" (353mm)
DROPOUT SIZE	74° 20mm (incl. chain tensioner for 10, 15 & 20mm hub axle)
HEAD TUBE ANGLE	74°
SEAT TUBE ANGLE	71°
HEAD TUBE SIZE (full int.)	tapered 1-1/8" - 1.5" (125mm)
SEAT POST SIZE	27.2mm
SEAT TUBE LENGTH	231mm
BOTTOM BRACKET TYPE	Euro, threaded, BSA 68mm
BOTTOM BRACKET HEIGHT	11.6"
WHEEL SIZE	20 x 1.75"
RIDER AREA	TBA
EXTRAS	<ul style="list-style-type: none">· super lightweight alloy frame (200g less than the Helium frame)· x2 world championship wins· Paradigm superior tubing· forged and CNC machined dropout with integrated chain tensioner· disc brake compatible with Helium Pro disc brake mount
WEIGHT	TBA

● COLOR - matt black

21
20 PARTS AND ACCESSORIES

QUARTZ PRO L FRAME

MATERIAL	Hydroformed 6061 alloy, Paradigm tubing
TOP TUBE LENGTH (actual)	20.9" (530mm)
CHAIN STAY LENGTH (min.)	13.9" (353mm)
DROPOUT SIZE	20mm (incl. chain tensioner for 10, 15 & 20mm hub axle)
HEAD TUBE ANGLE	74°
SEAT TUBE ANGLE	71°
HEAD TUBE SIZE (full int.)	tapered 1-1/8" - 1.5" (125mm)
SEAT POST SIZE	27.2mm
SEAT TUBE LENGTH	231mm
BOTTOM BRACKET TYPE	Euro, threaded, BSA 68mm
BOTTOM BRACKET HEIGHT	11.6"
WHEEL SIZE	20 x 1.75"
RIDER AREA	532.6mm
EXTRAS	<ul style="list-style-type: none">· super lightweight alloy frame (200g less than the Helium frame)· x2 world championship wins· Paradigm superior tubing· forged and CNC machined dropout with integrated chain tensioner· disc brake compatible with Helium Pro disc brake mount
WEIGHT	TBA

● COLOR - matt black



RADIO
RACELINE

P. 21

QUARTZ PRO XL FRAME

MATERIAL	Hydroformed 6061 alloy, Paradigm tubing
TOP TUBE LENGTH (actual)	21.25" (540mm)
CHAIN STAY LENGTH (min.)	14.5" (368mm)
DROPOUT SIZE	20mm (incl. chain tensioner for 10, 15 & 20mm hub axle)
HEAD TUBE ANGLE	74°
SEAT TUBE ANGLE	71°
HEAD TUBE SIZE (full int.)	tapered 1-1/8" - 1.5" (125mm)
SEAT POST SIZE	27.2mm
SEAT TUBE LENGTH	231mm
BOTTOM BRACKET TYPE	Euro, threaded, BSA 68mm
BOTTOM BRACKET HEIGHT	11.6"
WHEEL SIZE	20 x 1.75"
RIDER AREA	540.7mm
EXTRAS	<ul style="list-style-type: none">· super lightweight alloy frame (200g less than the Helium frame)· x2 world championship wins· Paradigm superior tubing· forged and CNC machined dropout with integrated chain tensioner· disc brake compatible with Helium Pro disc brake mount
WEIGHT	1.655g / 3.64lbs

● **COLOR** - matt black

21
20 PARTS AND ACCESSORIES

QUARTZ PRO XXL FRAME

MATERIAL	Hydroformed 6061 alloy, Paradigm tubing
TOP TUBE LENGTH (actual)	21.75" (552mm)
CHAIN STAY LENGTH (min.)	14.8" (376mm)
DROPOUT SIZE	20mm (incl. chain tensioner for 10, 15 & 20mm hub axle)
HEAD TUBE ANGLE	74°
SEAT TUBE ANGLE	71°
HEAD TUBE SIZE (full int.)	tapered 1-1/8" - 1.5" (125mm)
SEAT POST SIZE	27.2mm
SEAT TUBE LENGTH	231mm
BOTTOM BRACKET TYPE	Euro, threaded, BSA 68mm
BOTTOM BRACKET HEIGHT	11.6"
WHEEL SIZE	20 x 1.75"
RIDER AREA	551.9mm
EXTRAS	<ul style="list-style-type: none">· super lightweight alloy frame (200g less than the Helium frame)· x2 world championship wins· Paradigm superior tubing· forged and CNC machined dropout with integrated chain tensioner· disc brake compatible with Helium Pro disc brake mount
WEIGHT	TBA

● **COLOR** - matt black



RADIO
RACELINE

P. 22

QUARTZ PRO XXXL FRAME

MATERIAL	Hydroformed 6061 alloy, Paradigm tubing
TOP TUBE LENGTH (actual)	22.25" (565mm)
CHAIN STAY LENGTH (min.)	14.8" (376mm)
DROPOUT SIZE	20mm (incl. chain tensioner for 10, 15 & 20mm hub axle)
HEAD TUBE ANGLE	74°
SEAT TUBE ANGLE	71°
HEAD TUBE SIZE (full int.)	tapered 1-1/8" - 1.5" (125mm)
SEAT POST SIZE	27.2mm
SEAT TUBE LENGTH	231mm
BOTTOM BRACKET TYPE	Euro, threaded, BSA 68mm
BOTTOM BRACKET HEIGHT	11.6"
WHEEL SIZE	20 x 1.75"
RIDER AREA	564.2mm
EXTRAS	<ul style="list-style-type: none">· super lightweight alloy frame (200g less than the Helium frame)· x2 world championship wins· Paradigm superior tubing· forged and CNC machined dropout with integrated chain tensioner· disc brake compatible with Helium Pro disc brake mount
WEIGHT	TBA

● COLOR - matt black

21
20 PARTS AND ACCESSORIES

QUARTZ PRO XXXXL FRAME

MATERIAL	Hydroformed 6061 alloy, Paradigm tubing
TOP TUBE LENGTH (actual)	22.5" (572mm)
CHAIN STAY LENGTH (min.)	15.2" (386mm)
DROPOUT SIZE	20mm (incl. chain tensioner for 10, 15 & 20mm hub axle)
HEAD TUBE ANGLE	74°
SEAT TUBE ANGLE	71°
HEAD TUBE SIZE (full int.)	tapered 1-1/8" - 1.5" (125mm)
SEAT POST SIZE	27.2mm
SEAT TUBE LENGTH	231mm
BOTTOM BRACKET TYPE	Euro, threaded, BSA 68mm
BOTTOM BRACKET HEIGHT	11.6"
WHEEL SIZE	20 x 1.75"
RIDER AREA	570.9mm
EXTRAS	<ul style="list-style-type: none">· super lightweight alloy frame (200g less than the Helium frame)· x2 world championship wins· Paradigm superior tubing· forged and CNC machined dropout with integrated chain tensioner· disc brake compatible with Helium Pro disc brake mount
WEIGHT	TBA

● COLOR - matt black



SOLAR PRO L - PRO XXL



NEW PRODUCT

● COLOR - matt black



21
20 PARTS AND
ACCESSORIES

* Final product will vary in appearance! Image shows the Solar Pro XL model only.

RADIO
RACELINE
P. 24

SOLAR PRO L FRAME

MATERIAL	high performance TORAYCA carbon fiber
TOP TUBE LENGTH (actual)	20.75" (527mm)
TOP TUBE LENGTH (effective)	TBA
CHAIN STAY LENGTH (min.)	14.25" (362mm)
DROPOUT SIZE	15mm
HEAD TUBE ANGLE	74.5°
SEAT TUBE ANGLE	71°
HEAD TUBE SIZE (full int.)	tapered 1-1/8" - 1.5" (120mm)
SEAT POST SIZE	27.2mm
SEAT TUBE LENGTH	238mm
BOTTOM BRACKET TYPE	Euro, threaded, BSA 68mm
BOTTOM BRACKET HEIGHT	11.6"
WHEEL SIZE	20 x 1.75"
EXTRAS	<ul style="list-style-type: none">· full monocoque technology· internal cable routing· laboratory tested for superior strength and stiffness
WEIGHT	TBA

● **COLOR** - matt black

SOLAR PRO XL FRAME

MATERIAL	high performance TORAYCA carbon fiber
TOP TUBE LENGTH (actual)	21.25" (540mm)
TOP TUBE LENGTH (effective)	22.5" (571 mm)
CHAIN STAY LENGTH (min.)	14.5" (368mm)
DROPOUT SIZE	15mm
HEAD TUBE ANGLE	74.5°
SEAT TUBE ANGLE	71°
HEAD TUBE SIZE (full int.)	tapered 1-1/8" - 1.5" (120mm)
SEAT POST SIZE	27.2mm
SEAT TUBE LENGTH	238mm
BOTTOM BRACKET TYPE	Euro, threaded, BSA 68mm
BOTTOM BRACKET HEIGHT	11.6"
WHEEL SIZE	20 x 1.75"
EXTRAS	<ul style="list-style-type: none">· full monocoque technology· internal cable routing· laboratory tested for superior strength and stiffness
WEIGHT	1.215kg (2.68lbs)

● **COLOR** - matt black



SOLAR *PRO XXL FRAME*



MATERIAL	high performance TORAYCA carbon fiber
TOP TUBE LENGTH (actual)	21.75" (553mm)
TOP TUBE LENGTH (effective)	22.9" (584mm)
CHAIN STAY LENGTH (min.)	14.5" (368mm)
DROPOUT SIZE	15mm
HEAD TUBE ANGLE	74.5°
SEAT TUBE ANGLE	71°
HEAD TUBE SIZE (full int.)	tapered 1-1/8" - 1.5" (120mm)
SEAT POST SIZE	27.2mm
SEAT TUBE LENGTH	238mm
BOTTOM BRACKET TYPE	Euro, threaded, BSA 68mm
BOTTOM BRACKET HEIGHT	11.6"
WHEEL SIZE	20 x 1.75"
RIDER AREA	540.7mm
EXTRAS	<ul style="list-style-type: none">· full monocoque technology· internal cable routing· laboratory tested for superior strength and stiffness
WEIGHT	TBA

● **COLOR** - matt black

PRO CHAIN TENSIONER



MATERIAL	full cnc machined 606-T6 alloy
EXTRAS	· for 10mm and 15mm axles · 22mm of adjustment
WEIGHT	TBA



HELIUM EXPERT DISC BRAKE MOUNT



MATERIAL	full cnc machined 606-T6 alloy
EXTRAS	compatible with Helium Mlini, Junior and Expert frames
WEIGHT	TBA

HELIUM PRO DISC BRAKE MOUNT

MATERIAL	full cnc machined 606-T6 alloy
EXTRAS	<ul style="list-style-type: none">· compatible with Helium Pro and Quartz frames· available for 10mm, 15mm and 20mm hub axles
WEIGHT	TBA



RACELINE *DISC BRAKE ROTOR*



MATERIAL	stainless steel
SIZE	120mm
EXTRAS	· 6 bolt attachment · smaller sizes specific for BMX race
WEIGHT	TBA

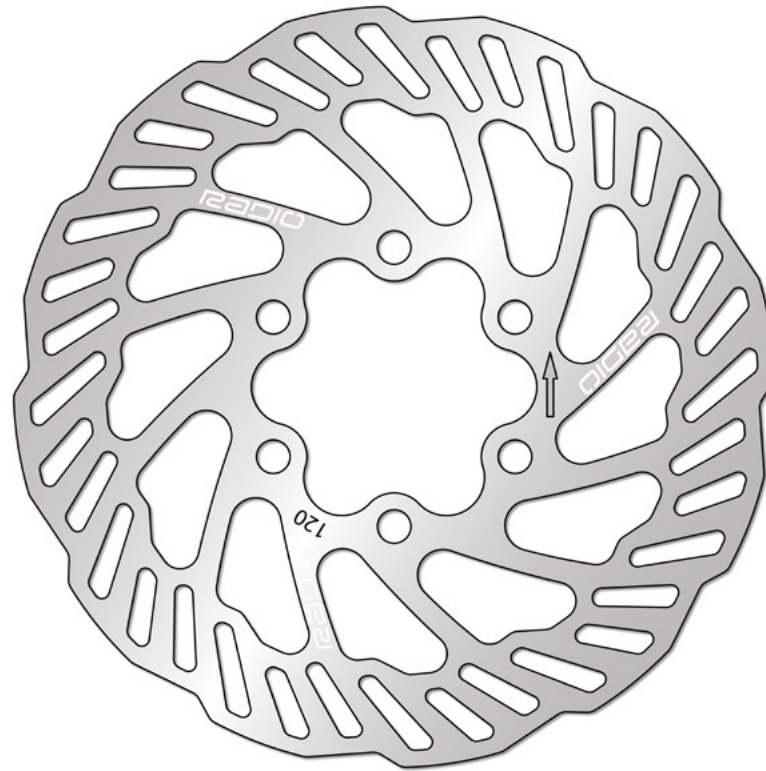

RACELINE EXTERNAL EURO BB SET



MATERIAL	full cnc machined 606-T6 alloy cups
SIZE	external mounted bearings, 68-73mm BSA 1.37" 24T
EXTRAS	<ul style="list-style-type: none">• includes spacers• for 24mm spindle cranks
WEIGHT	TBA

- **COLOR** - black
- **COLOR** - cyan
- **COLOR** - red



21 |
20 PARTS AND
ACCESSORIES

* Final product will vary in appearance!

RADIO
RACELINE
P. 30

RACELINE 1" INTEGRATED HEADSET



MATERIAL	full cnc machined 6016-T6 top cap, 7mm tall
SIZE	integrated bearings (45x45)
EXTRAS	· for 1" headtubes · includes Radio starnut
WEIGHT	TBA

- **COLOR** - black
- **COLOR** - cyan
- **COLOR** - red

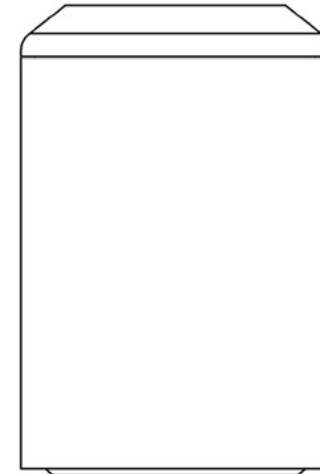

RACELINE 1 1/8" INTEGRATED HEADSET



MATERIAL	full cnc machined 6016-T6 top cap, 8.3mm tall
SIZE	campy spec integrated bearings (45x45)
EXTRAS	includes Radio starnut
WEIGHT	TBA

- **COLOR** - black
- **COLOR** - cyan
- **COLOR** - red

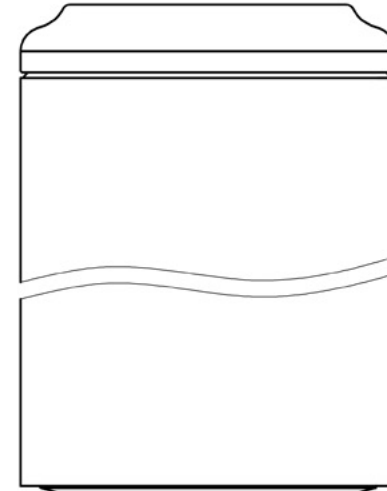

RACELINE 1 1/8" - 1.5" INTEGRATED HEADSET



MATERIAL	full cnc machined 6016-T6 top cap, 8.3mm tall
SIZE	integrated bearings (45x45)
EXTRAS	· for tapered 1 1/8" - 1.5" headtubes · includes Radio starnut
WEIGHT	TBA

- **COLOR** - black
- **COLOR** - cyan
- **COLOR** - red

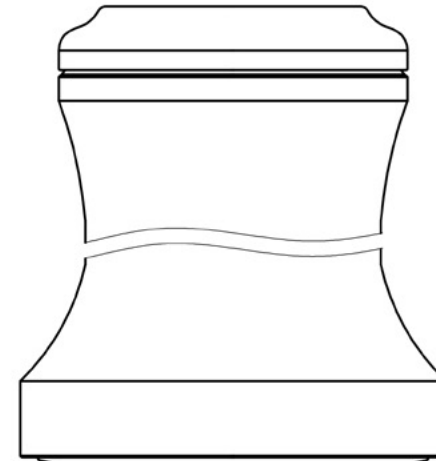

SOLAR FORK



MATERIAL	high performance TORAYCA carbon fiber legs and steerer
SIZE	1-1/8"-1.5" tapered steerer
DROPOUTS	20mm
OFFSET	32mm +/-1.5mm
EXTRAS	<ul style="list-style-type: none">· incl. Stem lock & adapters for 10mm female bolts· laboratory tested for superior strength and stiffness· This fork exceeds EN16054 testing for BMX race forks
WEIGHT LIMIT	maximum rider weight 115kg
WEIGHT	490g



COBALT JUNIOR STEM



MATERIAL	casted body, forged cap, 6061-T6 alloy
STEERER CLAMPING SIZE	1"
BAR CLAMPING SIZE	22.2mm
REACH	40mm
RISE	23mm
STACK	30mm
EXTRAS	<ul style="list-style-type: none">· weight saving cap and side pocket· fits to 1" steerer tube forks
WEIGHT	TBA

● **COLOR** - black



21 |

20 PARTS AND ACCESSORIES

RADIO
RACELINE

P. 35

COBALT PRO STEM



MATERIAL	casted body, forged cap, 6061-T6 alloy
STEERER CLAMPING SIZE	1 1/8"
CLAMPING SIZE	22.2mm
REACH	50mm
RISE	23mm
STACK	30mm
EXTRAS	weight saving cap and side pocket
WEIGHT	TBA

● **COLOR** - black



XENON PRO STEM



MATERIAL	full cold forged 6061-T6 alloy
STEERER CLAMPING SIZE	1 1/8"
CLAMPING SIZE	22.2mm
REACH	53mm
RISE	23mm
STACK	30mm
EXTRAS	cnc machined cap and side pocket
WEIGHT	TBA

- **COLOR** - black
- **COLOR** - high polished



NEON PRO STEM



MATERIAL	full cnc machined 6061-T6 alloy
STEERER CLAMPING SIZE	1 1/8"
CLAMPING SIZE	22.2mm
REACH	48mm, 54mm, 60mm
RISE	27mm
STACK	32.5mm
EXTRAS	<ul style="list-style-type: none">· wider 48mm cap with cut-out· offset rear slot to improve clamping
WEIGHT	TBA

● COLOR - black



XENON MICRO HANDLEBAR



MATERIAL	6061-T6 alloy
TUBING	Internally butted main tube
BAR CLAMPING SIZE	22.2mm
RISE	2"
WIDTH	23.25"
BACK SWEEP	6°
UP SWEEP	2°
EXTRAS	super lightweight alloy handlebar
WEIGHT	TBA

● COLOR - black



XENON MINI HANDLEBAR



MATERIAL	6061-T6 alloy
TUBING	Internally butted main tubes
BAR CLAMPING SIZE	22.2mm
RISE	3" or 4"
WIDTH	23.25" or 23.65
BACK SWEEP	6°
UP SWEEP	2°
EXTRAS	· super lightweight alloy handlebar
WEIGHT	TBA

● COLOR - black



21 |
20 PARTS AND
ACCESSORIES

* Final product will vary in appearance!

RADIO
RACERLINE
P. 40

XENON JUNIOR HANDLEBAR



MATERIAL	6061-T6 alloy
TUBING	Internally butted main tubes
BAR CLAMPING SIZE	22.2mm
RISE	4.5"
WIDTH	24"
BACK SWEEP	6°
UP SWEEP	2°
EXTRAS	<ul style="list-style-type: none">· super lightweight alloy handlebar· unique externally butted 19mm cross tube
WEIGHT	TBA

- **COLOR** - black
- **COLOR** - cyan
- **COLOR** - red



XENON EXPERT HANDLEBAR



MATERIAL	6061-T6 alloy
TUBING	Internally butted main tubes
BAR CLAMPING SIZE	22.2mm
RISE	5.5"
WIDTH	24.8"
BACK SWEEP	7°
UP SWEEP	2°
EXTRAS	<ul style="list-style-type: none">· super lightweight alloy handlebar· unique externally butted 19mm cross tube
WEIGHT	TBA

- **COLOR** - black
- **COLOR** - cyan
- **COLOR** - red



XENON EXPERT XL HANDLEBAR



MATERIAL	6061-T6 alloy
TUBING	Internally butted main tubes
BAR CLAMPING SIZE	22.2mm
RISE	6.5"
WIDTH	27.15"
BACK SWEEP	7°
UP SWEEP	2°
EXTRAS	<ul style="list-style-type: none">· super lightweight alloy handlebar· unique externally butted 19mm cross tube
WEIGHT	TBA

- **COLOR** - black
- **COLOR** - cyan
- **COLOR** - red



NEON PRO HANDLEBAR

MATERIAL	fully heat treated M2 crmo
TUBING	multiple butted main tube, mechanically formed cross tube
BAR CLAMPING SIZE	22.2mm
RISE	7", 7.5", 8", 8.5", 9"
WIDTH	27.5", 28", 28.5", 29", 29.15"
BACK SWEEP	6.5°
UP SWEEP	2.5°
EXTRAS	lightweight crmo handlebar
WEIGHT	TBA

- **COLOR** - black
- **COLOR** - white

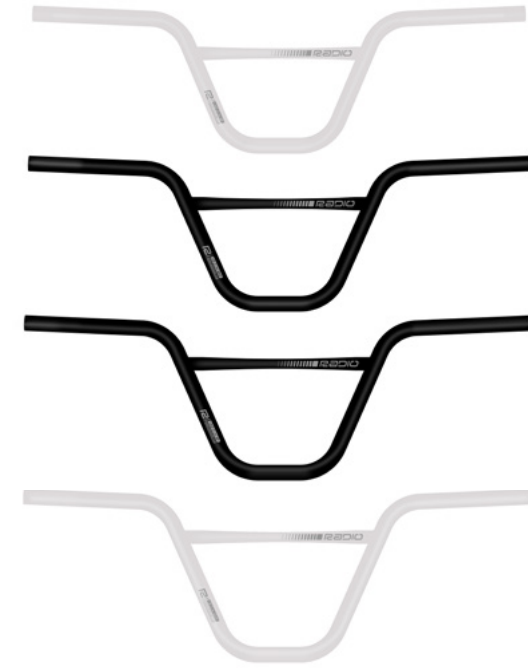

OXYGEN TIRE



MATERIAL	high quality racing rubber compound
CONSTRUCTION	120 TPI casing, folding bead
INFLATED WIDTH	1.6" (40mm), 1.75" (43mm), 1.95" (46mm)
INFLATED DIAMETER	1.6" (496mm), 1.75" (495mm), 1.95" (510mm)
EXTRAS	<ul style="list-style-type: none">· high pressure rated (100psi)· light weight, high-performance race tire· smooth central area for speed, unique outer tread to increase traction and grip on all surfaces· micro knurling for advanced grip performance
WEIGHT	<ul style="list-style-type: none">1.6" - 365g/12.9oz1.75" - 445g/15.6oz1.95" - 470g/16.4oz



OXYGEN TIRE TUBELESS READY



MATERIAL	high quality racing rubber compound
CONSTRUCTION	60 TPI casing, folding bead, tubeless ready
INFLATED WIDTH	1.6" (40mm), 1.75" (43mm), 1.95" (46mm)
INFLATED DIAMETER	1.6" (496mm), 1.75" (495mm), 1.95" (510mm)
EXTRAS	<ul style="list-style-type: none">· high pressure rated (100psi)· light weight, high-performance race tire· compatible with tubeless ready rims· smooth central area for speed, unique outer tread to increase traction and grip on all surfaces· micro knurling for advanced grip performance
WEIGHT	<ul style="list-style-type: none">1.6" - 400g/14oz1.75" - 460g/16.1oz1.95" - 500g/17.6oz



CLIPPER JUNIOR RIM



MATERIAL	6061-T6 alloy
CONSTRUCTION	sleeved joint
SIZE	20"X 1 1/8"-1 3/8" (451)
WIDTH	19.4mm
SPOKE HOLES	28h
EXTRAS	<ul style="list-style-type: none">· light weight junior sized rim· available in three colours
WEIGHT	TBA

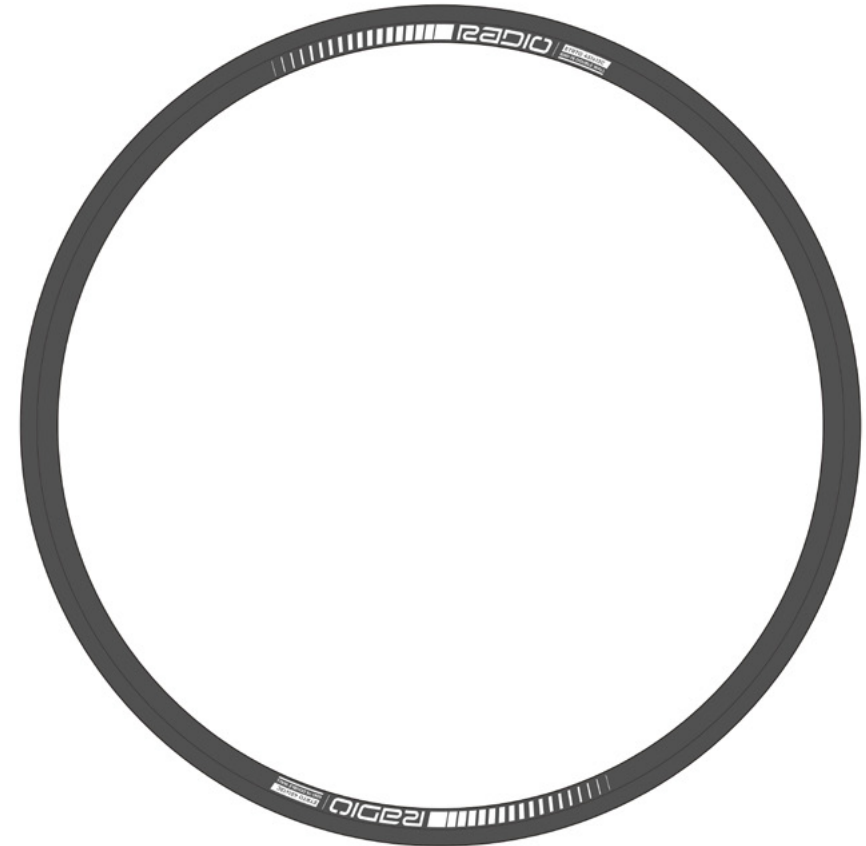

21 |
20 PARTS AND
ACCESSORIES

* Final product will vary in appearance!

RADIO
RACELINE
P. 47

CLIPPER *EXPERT RIM*



MATERIAL	6061-T6 alloy
CONSTRUCTION	pinned join, tubeless ready
SIZE	20"X1.4"-1.75" (406)
WIDTH	25mm
SPOKE HOLES	28h
EXTRAS	· light weight expert sized rim · tubeless ready
WEIGHT	TBA

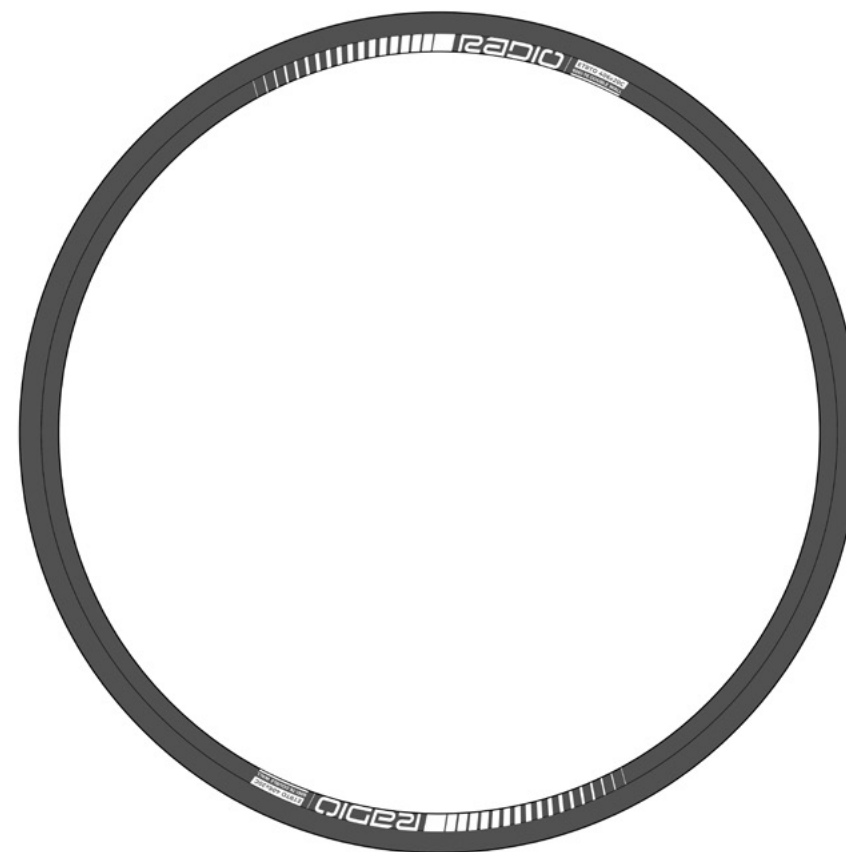
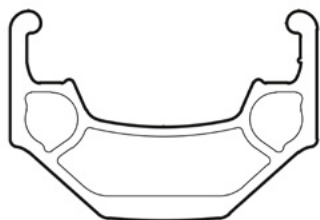

21 |
20 PARTS AND
ACCESSORIES

* Final product will vary in appearance!

RADIO
RACELINE
P. 48

ARGON PRO RIM



MATERIAL	6061-T6 alloy
CONSTRUCTION	flash welded join, tubeless ready
SIZE	20"X1.6"-1.95" (406)
WIDTH	28mm
SPOKE HOLES	available as 32h or 36h
EXTRAS	<ul style="list-style-type: none">· lightweight pro level welded rim· front and rear specific models· tubeless ready
WEIGHT	TBA

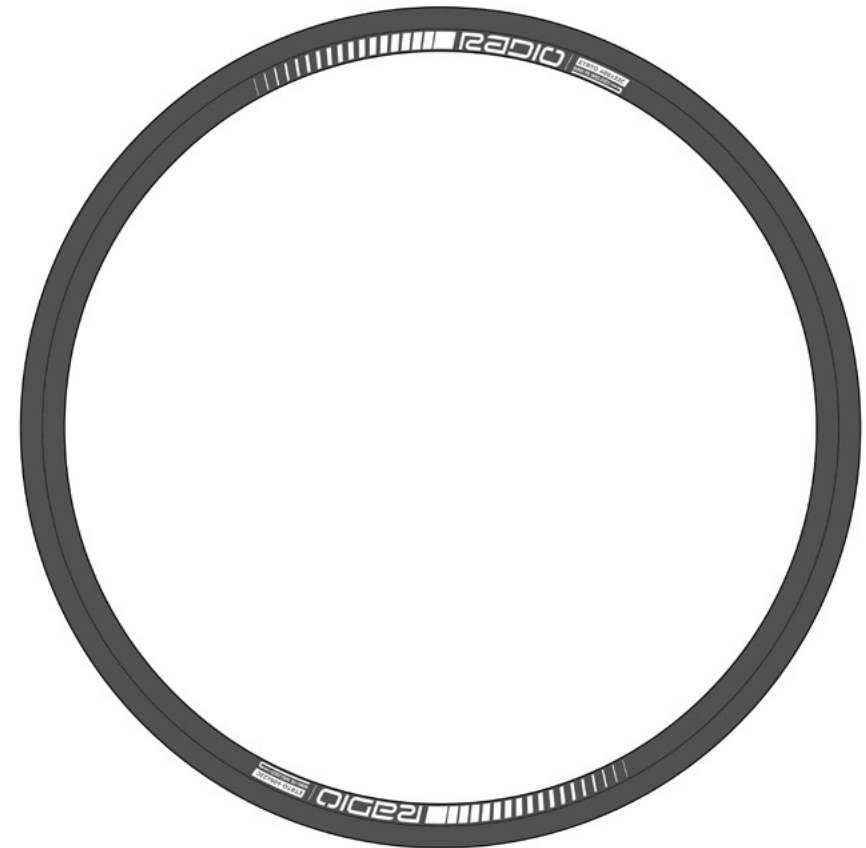
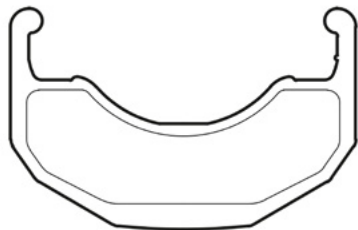

SOLAR RIM



MATERIAL	high performance TORAYCA carbon fiber
CONSTRUCTION	tubeless ready
SIZE	20"X1.6"-1.95" (406)
WIDTH	28mm
SPOKE HOLES	36h
EXTRAS	<ul style="list-style-type: none">· pro level full carbon fiber rim· front and rear specific models· tubeless ready
WEIGHT	300g



RACELINE TUBELESS VALVE



MATERIAL	light weight alloy
VALVE	presta valve
SIZE	40mm or 60mm
EXTRAS	<ul style="list-style-type: none">· x3 color options (black; red; blue)· comes as pair, includes locknut· compatible with Argon and Solar rims· high pressure compatible
WEIGHT	TBA

● **COLOR** - black

● **COLOR** - cyan

● **COLOR** - red



SOLAR *PRO RIM TAPE*



MATERIAL	high quality race rubber
WIDTH	20"X 1 1/8"-1 3/8" (451), 20"X1.4"-1.95" (406)
VALVE	presta valve
EXTRAS	<ul style="list-style-type: none">· two size options· high pressure compatible· maximum tube protection from spokes and burs on rims· designed to fit both the Solar rim and the Argon rim, tubeless ready
WEIGHT	TBA



21 |

20 PARTS AND
ACCESSORIES

* Final product will vary in appearance!

RADIO
RACELINE

P. 52

CLIPPER RIM TAPE



MATERIAL	heavy duty nylon
WIDTH	available as 16mm (Junior) or 20mm (Expert) version
EXTRAS	maximum tube protection from spokes and burs on rims
WEIGHT	TBA



21 |

20 PARTS AND ACCESSORIES

* Final product will vary in appearance!

RADIO
RACELINE

P. 53

RACELINE STICKER PACK



SIZE various sizes - 28 assorted stickers per set
EXTRAS high quality stickers, perfect for outdoor usage



RACELINE AUTHORIZED DEALER STICKER



SIZE

130mm x 130mm

EXTRAS

- high quality Authorized Dealer sticker
- perfect for usage on shop windows



RACELINE SHOP BANNER



SIZE

140cm x 30cm

EXTRAS

- ideal for usage in shop and event spaces
- comes with eyelets for ease of hanging



RACELINE CONTEST BANNER



SIZE

200cm x 60cm

EXTRAS

- super durable PVC material
- ideal for indoor and outdoor usage
- comes with eyelets for ease of hanging



21
20

PARTS AND
ACCESSORIES

* Final product will vary in appearance!

RADIO
RACELINE

P. 57

RACELINE WATER BOTTLE



MATERIAL	body PP, cap and tube LD-PE
SIZE	500ml
EXTRAS	includes extra long straw lightweight and squeezable bottle design BPA free construction lockable valve
WEIGHT	TBA



21 |
20 PARTS AND
ACCESSORIES

RADIO
RACELINE
P. 58



WE MAKE THINGS GmbH
Richard-Byrd-Str. 12
50829 Cologne / Germany
mail@radiobikes.com

© WE MAKE THINGS GmbH, all rights reserved.